

**PUMP, VALVE AND DAM
EQUIPMENT
PRODUCT CATALOGUE**



Since 1984, SEMSAN PUMP is main mechanical equipment and specific process pumps manufacturer for most important projects of Turkey. SEMSAN is most wanted company in Turkey market when SEMSAN PUMP established.

SEMSAN PUMP relocated in Samsun organized industrial zone at 2002 for growing marketing requests.

SEMSAN PUMP has 5000m2 work field in Samsun Industrial zone. Our company has 2x2000 kg. + 2x750 kg. Inductotherm brand twin induction furnaces. We can offer our brands manufacturing and high-tech forming and induction equipment's we can produce stainless steel and ductile products.

SEMSAN PUMP has TSE certificates on all products and all processes have to obey TSE ISO 9001:2008, TSE-EN-ISO 14001, İSG-OHSAS TS18001 quality management.

SEMSAN PUMP also has European CE Declaration of conformity for pumps and valves.

SEMSAN PUMP has innovative perspective, daily gaining new features on our company. Also SEMSAN PUMP check updates and newest products in the marketing world wide and keeps updating and upgrading self.

CERTIFICATION

- K-Q TSE ISO EN 9000 QUALITY MANAGEMENT SYSTEM
- TSE İSG-OHSAS TS 18001 HEALTH AND SAFETY MANAGEMENT SYSTEM
- Ç-E TSE-ISO-EN 14000 ENVIROMENTAL MANAGEMENT SYSTEM
- TS EN 593 BUTTERFLY VALVE
- TS EN 12334 CHECK VALVE
- TS 12599 SUBMERSIBLE SEWAGE PUMP
- TSE K 461 DISMANTLIG JOINT
- 97/23/EC PRESSURE EQUIPMENT CASTING CERTIFICATE
- CE DECLARATION OF CONFORMITY ABOUT PUMPS
- TS 12873 SERVICE QUALIFICATION CERTIFICATE - PUMPS
- TS 12844 SERVICE QUALIFICATION CERTIFICATE - VALVE
- WRAS - COATING AND EPDM SEALING SUITABLE FOR DRINKING WATER



ABOUT



MANUFACTURING

- FOUNDRY; 2x2000 kg + 2x750 kg Inductotherm Induction Furnace
- CNC Machining Department
- Electrostatic Epoxy Coating Line
- Double Compound Wet Epoxy Line
- Quality Control
- Material Laboratory: Spectrometer, Tensile Strength Test Machine, Microstructure Analysis Microscope, Hardness Tests
- Hydrostatic Pressure Tests for EN 12266 -1,2
- Pump Performance Tests for ISO 9906
- Material Certification for EN 10204 3.1
- Coating Thickness, Pull of and Spark Test
- Surface Roughness Tests

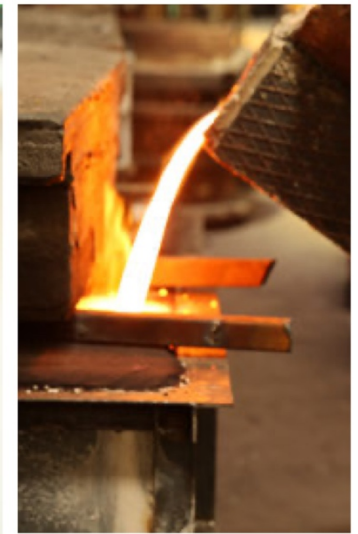
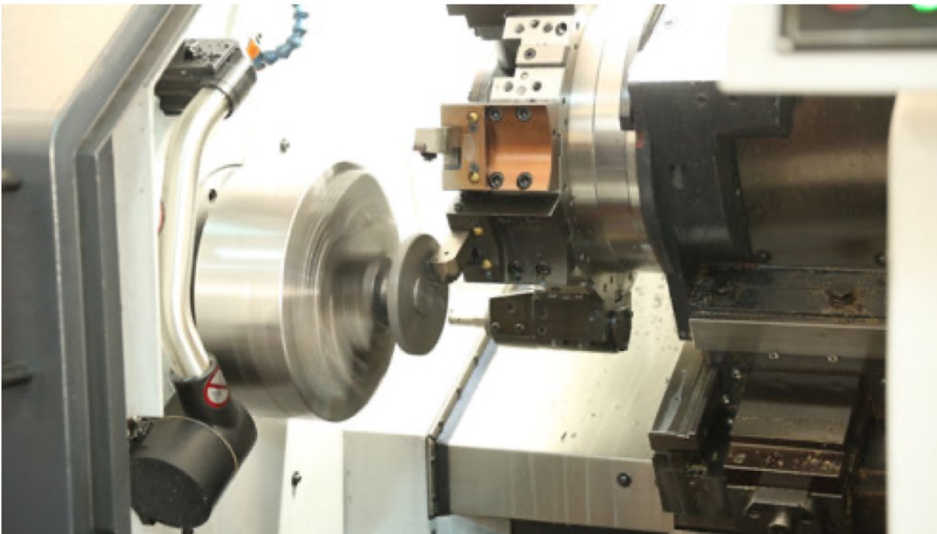



ADVANTAGES

- Compact Design (EN 558-1 Series 14)
- Low Operation Torque for Bigger Diameters with Double Eccentric
- Low maintenance cost
- Leakage Tests, EN 12266 Class A (completely tightness)

DESIGN

- TS EN 593 Certificated
- Double Flange
- Double Eccentric
- Flanges DIN EN 1092 PN 10 – PN40
- Valve Shaft Double Offset
- Face to Face EN 558-1 Series 14 (DIN 3202, F4) (Short Pattern is Optional)
- Mechanical Position Indicator and Limit stops on Gear Box
- Body Sealing Surface;
- Corrosion - Resistant Stainless Welded AISI 316 and Microfinished.
- Adjustable and Replaceable Sealing Ring
- EN 12516 – 1 Steel Welded Design (Optional)
- Max Operation Temperature 50 °C (120 °C Optional)

APPLICATION AREAS

- Drinking Water Lines
- Drinking Water Treatment Plants
- Waste Water Treatment Plants
- Pumping Stations
- Irrigation Projects
- Dams and Reservoirs
- Neutral Gas and Cool Power Plants
- Hydroelectric Power Plants
- Industrial Plants

OPERATION

- Handwheel
- Electrical Actuator
- Pneumatic Actuator
- Hydraulic Actuator
- On – Off or Modulating Operation

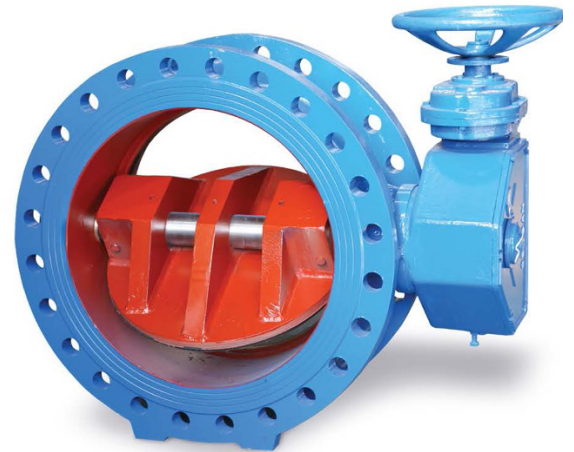

CORROSION PROTECTION

- Electrostatic Powder Coating for Drinking Water
- Zinc – Rich Epoxy Primer
- Coal – Tar Epoxy
- Glass Flake Epoxy
- Enamel Epoxy for Ultraviolet
- Completely Stainless Steel Design
- Ebonite Coating for Seawater

LAST QUALITY CONTROL EN 12266 – 1 CLASS A

Nominal Diameter (DN)	Nominal Pressure PN kg / cm2	Test Pressure		Max Pressure for Temperature 50 °C
		Body	Disk	
100.....2800	10	15	11	10
100.....2800	16	24	18	16
100.....2800	25	37,5	27,5	25
100.....2800	40	60	44	40

* All of dimensions and explanations has been given for information. SEMSAN reserve right to keep change all them off.

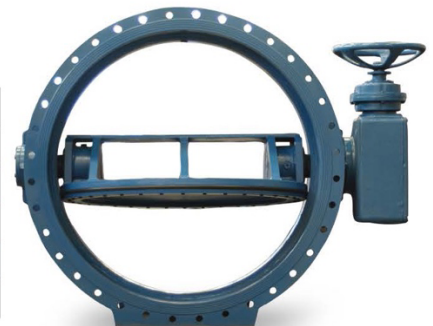



HYDRAULIC CONTROLLED CHECK BUTTERFLY VALVE (TURBINE INLET VALVE)

DN 250/2800 | PN 10 / 16 / 25 / 40

DESIGN

- TS EN 593 Certificated
- Double Flange
- Double Eccentric
- Flanges DIN EN 1092
- Valve Shaft Double Offset
- PN 10 – PN40
- Face to Face EN 558-1 Series 14 (DIN 3202, F4) (Short Pattern is Optional)
- Mechanical Position Indicator and Limit Stops on Gear Box
- Body Sealing Surface; Corrosion - Resistant Stainless Welded AISI 316 and Microfinished.
- Adjustable and Replaceable Sealing Ring
- EN 12516 – 1 Steel Welded Design (Optional)
- Max Operation Temperature 50 °C

APPLICATION AREAS

- Turbine Inlet Valves in Hydroelectric Power Plants
- Emergency Shut Off Valves in Dams and Reservoirs
- Check Butterfly Valves for Pumping Stations

CORROSION PROTECTION

- Electrostatic Powder Coating for Drinking Water
- Zinch – Rich Epoxy Primer
- Coal – Tar Epoxy
- Glass Flake Epoxy
- Enamel Epoxy for Ultraviolet
- Completely Stainless Steel Design
- Ebonite Coating for Seawater

ADVANTAGES

- Opening and Closing With Hydraulic Piston
- Closing With Counter Weight
- High Security Coefficient
- Suddenly Shut-Off for Emergency
- Additional Limit Switch for Hydraulic Leakages
- Two Different Operation Adjust Valve

LAST QUALITY CONTROL EN 12266 – 1 CLASS A

Nominal Diameter (DN)	Nominal Pressure PN kg / cm ²	Test Pressure		Max Pressure for Temperature 50 °C
		Body	Disk	
250.....2800	10	15	11	10
250.....2800	16	24	18	16
250.....2800	25	37,5	27,5	25
250.....2800	40	60	44	40

* All of dimensions and explanations has been given for information. SEMSAN reserve right to keep change all them off.

TURBINE INLET VALVE – EMERGENCY SHUT OFF VALVES

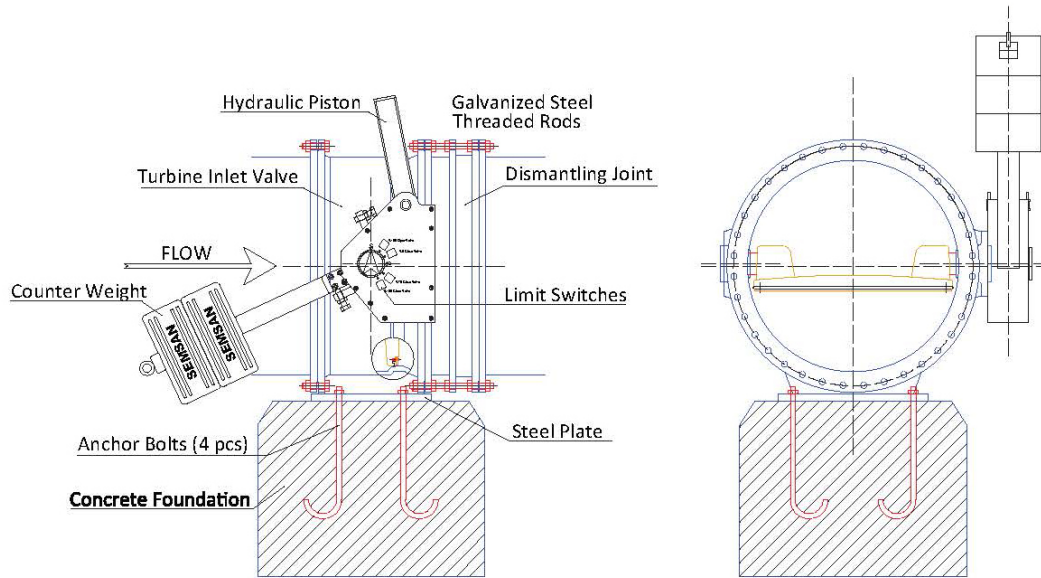

OPERATING PRINCIPLES

Check-Butterfly valve; It is the valve closed by weight fastened to valve shaft and opened by hydraulic pump. Oil pressure disappearing in hydraulic cylinder of the valve opened by hydraulic pump will be supported by accumulator having a diaphragm in the volume of 2,0 L, since S1 and S2 solenoid valves are closed. If cylinder pressure falls down from adjusted pressure, hydraulic pump will operate and increase system pressure. If adjustable pressure shifter doesn't operate, valve will start to close. When it is closed at the rate of 5 %, limit switch on the valve box cover will be closed, pump will operate, increase the system pressure and valve will come into the position of full open.

If close order comes to the valve because of extreme speed and low pressure, it sends 24 V current to the coil of S1 solenoid valve on hydraulic power unit. by opening of S1 solenoid valve, valve starts to close, it completes with high speed the closing ratio of 70 % and with low speed the remaining closing ratio of 30 %.

Valve closing at the ratio of 70 % closes limit switch on the valve box cover, sends 24 V DC current to the coil of S2 solenoid valve on the power unit. Solenoid valve operates and slowly closes 30 % of valve. There are 4 pieces limit switch on the valve box cover

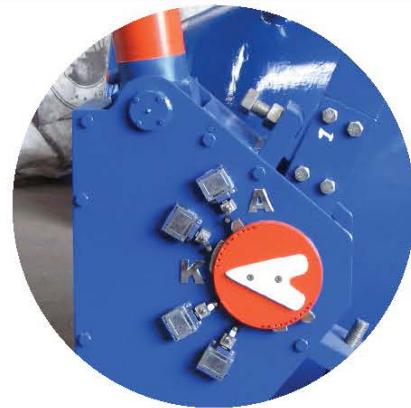

DOUBLE ECCENTRIC DOUBLE FLANGED BUTTERFLY VALVE

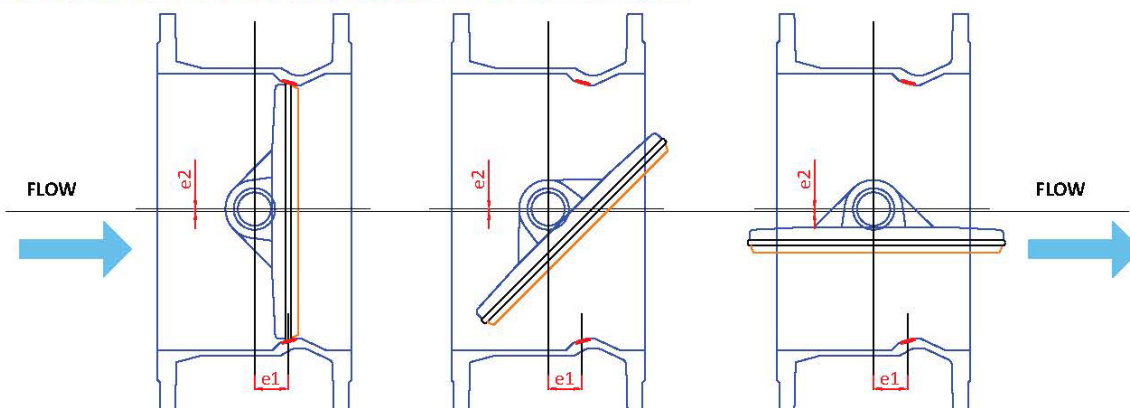

e1: Difference of Sealing Ring Seat Axis – Shaft Axis (For perfect contact of sealing ring to seat surface at flow direction)

e2: Difference of Disc Axis – Valve Axis (For low operation torque at opening direction)

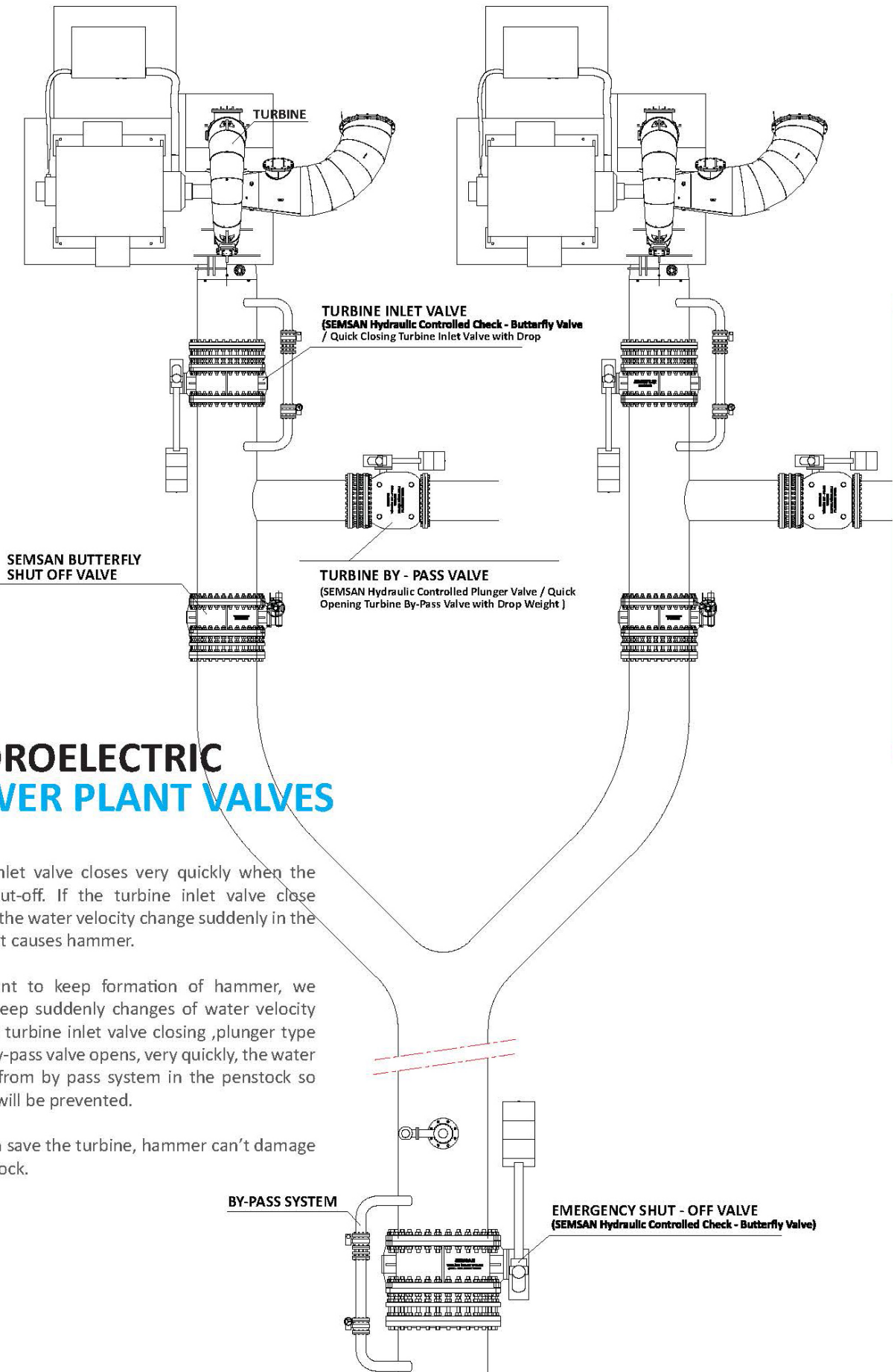

HYDROELECTRIC POWER PLANT VALVES

Turbine inlet valve closes very quickly when the turbine cut-off. If the turbine inlet valve close suddenly the water velocity change suddenly in the pipe and it causes hammer.

If we want to keep formation of hammer, we have to keep suddenly changes of water velocity when the turbine inlet valve closing ,plunger type turbine by-pass valve opens, very quickly, the water released from by pass system in the penstock so hammer will be prevented.

So we can save the turbine, hammer can't damage the penstock.

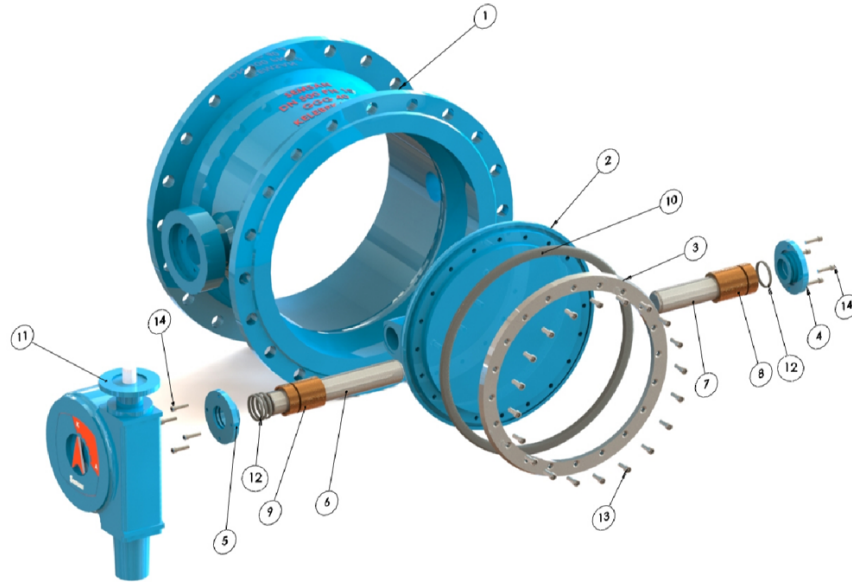

NO	PART	STANDART MATERIAL	OPTIONAL MATERIALS	
1	VALVE BODY	DUCTILE IRON GJS400.15 / GJS400.18 / GJS500.7 / GJS500.14	STAINLESS STEEL AISI 304 / AISI 316 / AISI 329 Duplex (S32900)	STEEL S235JR / S355J / GS C25
2	VALVE DISC	DUCTILE IRON GJS400.15 / GJS400.18 / GJS500.7 / GJS500.14	STAINLESS STEEL AISI 304 / AISI 316 / AISI 329 Duplex (S32900)	STEEL S235JR / S355J / GS C25
3	SEALING RING FLANGE	STAINLESS STEEL AISI 304 / AISI 316	DUCTILE IRON GJS400.15 / GJS400.18 / GJS500.7 / GJS500.14	STEEL S235JR / S355J
4	BLIND LID	DUCTILE IRON GJS400.15 / GJS400.18 / GJS500.7 / GJS500.14	STAINLESS STEEL AISI 304 / AISI 316 / AISI 329 Duplex (S32900)	STEEL S235JR / S355J / GS C25
5	SHAFT LID	DUCTILE IRON GJS400.15 / GJS400.18 / GJS500.7 / GJS500.14	STAINLESS STEEL AISI 304 / AISI 316 / AISI 329 Duplex (S32900)	STEEL S235JR / S355J / GS C25
6	CONTROL SHAFT	1.4021 (AISI420)	1.4057 (AISI431)	1.4462 (Duplex SS)
7	SHORT SHAFT	1.4021 (AISI420)	1.4057 (AISI431)	1.4462 (Duplex SS)
8	SHORT BUSH	GCuSn10	Derlin	PTFE
9	LONG BUSH	GCuSn10	Derlin	PTFE
10	SEALING RING	EPDM	NBR	VITON
11	CONTROL BOX	SEMSAN NDK SERIES (IP68)		
12	O-RING	EPDM	VITON	
13	INLET BOLTS	A2	A4	
14	OTHER BOLTS AND NUTS	8.8 GALVANISED	A2	A4
15	BODY SEAT	AISI 309L Si	AISI 316L Si	
16	COATING	ELECTROPOWDER EPOXY	WET EPOXY, GLASS FLAKE	EBONITE

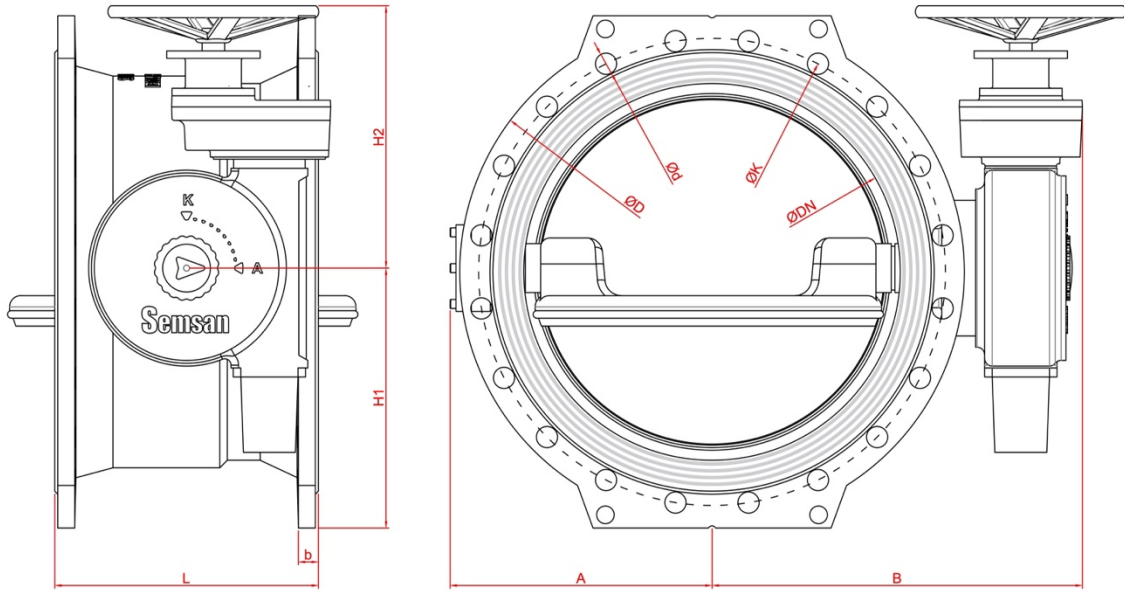

PN10	VALVE DIMENSIONS							FLANGE DIMENSIONS (in mm)					Weight (KG)
DN	Series 13	Series 14	L	A	B	H1	H2	D	K	No of Holes	d	b	
100	127	190	190	110	230	110	176	220	180	8	19	19	23,2
125	140	200	200	125	250	125	176	250	210	8	19	19	28,2
150	140	210	210	143	255	143	176	285	240	8	23	19	33,2
200	152	230	230	170	305	184	176	340	295	8	23	20	56,2
250	165	250	250	200	360	214	230	400	350	12	23	22	82
300	178	270	270	233	385	245	230	455	400	12	23	24,5	102
350	190	290	290	275	410	260	230	505	460	16	23	24,5	131
400	216	310	310	283	402	295	230	565	515	16	28	24,5	150
450	222	330	330	330	466	320	270	615	565	20	28	25,5	182
500	229	350	350	350	481	350	270	670	620	20	28	26,5	240
600	267	390	390	398	547	400	299	780	725	20	31	30	342
700	292	430	430	490	672	474	417	895	840	24	31	32,5	512
800	318	470	470	545	770	525	417	1015	950	24	34	35	652
900	330	510	510	586	813	572	482	1115	1050	28	34	37,5	898
1000	410	550	550	650	882	635	482	1230	1160	28	37	40	1162
1100	440	590	590	690	917	690	482	1340	1270	32	37	43	1408
1200	470	630	630	750	1063	750	560	1455	1380	32	41	45	1758
1300	500	670	670	830	1113	830	560	1570	1490	32	44	45	2278
1400	530	710	710	890	1158	860	715	1675	1590	36	44	46	2545
1500	560	750	750	930	1215	920	642	1785	1700	36	44	47,5	3543
1600	600	790	790	1000	1275	995	642	1915	1820	40	50	49	4233
1800	670	870	870	1100	1375	1090	642	2115	2020	44	50	52	5068
2000	760	950	950	1200	1525	1190	797	2325	2230	48	50	55	7180
2200	-	1030	1030	1315	1605	1225	797	2550	2440	52	56	59	9300
2400	-	1110	1110	1450	1760	1415	952	2760	2650	56	56	62	11400

PN16	VALVE DIMENSIONS							FLANGE DIMENSIONS (in mm)					Weight (KG)
	DN	Series 13	Series 14	L	A	B	H1	H2	D	K	No of Holes	d	
100	127	190	190	110	230	110	176	220	180	8	19	19	23,2
125	140	200	200	125	250	125	176	250	210	8	19	19	28,2
150	140	210	210	143	255	143	176	285	240	8	23	19	33,2
200	152	230	230	170	305	184	230	340	295	12	23	20	55
250	165	250	250	200	360	214	230	400	355	12	28	22	82
300	178	270	270	233	385	245	230	455	410	12	28	24,5	110
350	190	290	290	275	410	270	230	520	470	16	28	26,5	131
400	216	310	310	290	418	310	270	580	525	16	31	28	190
450	222	330	330	330	466	330	270	640	585	20	31	30	240
500	229	350	350	358	481	373	270	715	650	20	34	31,5	300
600	267	390	390	420	547	430	299	840	770	20	37	36	503
700	292	430	430	490	697	480	434	910	840	24	37	39,5	688
800	318	470	470	545	802	530	482	1025	950	24	40	43	793
900	330	510	510	586	813	577	482	1125	1050	28	40	46,5	988
1000	410	550	550	650	882	648	482	1255	1170	28	43	50	1338
1100	440	590	590	690	917	700	482	1355	1270	32	43	53,5	1588
1200	470	630	630	750	1113	765	560	1485	1390	32	49	57	2108
1300	500	670	670	830	1158	845	560	1585	1490	32	49	58	2563
1400	530	710	710	890	1148	870	642	1685	1590	36	49	60	2963
1500	560	750	750	930	1215	940	642	1820	1710	36	57	62,5	3773
1600	600	790	790	1000	1275	1000	797	1930	1820	40	57	65	4468
1800	670	870	870	1100	1375	1100	797	2130	2020	44	57	70	5320
2000	760	950	950	1250	1585	1280	952	2345	2230	48	62	75	7450

PN25	VALVE DIMENSIONS							FLANGE DIMENSIONS (in mm)					Weight (KG)
	DN	Series 13	Series 14	L	A	B	H1	H2	D	K	No of Holes	d	
100	127	190	190	110	230	110	176	220	180	8	19	19	29,2
125	140	200	200	135	250	135	176	270	220	8	28	19	33,2
150	140	210	210	150	290	150	230	300	250	8	28	20	50
200	152	230	230	180	340	194	230	360	310	12	28	22	85
250	165	250	250	213	390	225	264	425	370	12	31	24,5	90
300	178	270	270	243	395	255	264	485	430	16	31	27,5	140
350	190	290	290	278	440	285	264	555	490	16	34	30	185
400	216	310	310	310	429	325	299	620	550	16	37	32	267
450	222	330	330	335	477	350	299	670	600	20	37	34,5	387
500	229	350	350	365	575	380	434	730	660	20	37	36,5	468
600	267	390	390	423	630	438	434	845	770	20	40	42	613
700	292	430	430	490	704	500	482	960	875	24	43	46,5	938
800	318	470	470	545	802	560	482	1085	990	24	49	51	1168
900	330	510	510	593	813	612	482	1185	1090	28	49	55,5	1848
1000	410	550	550	660	882	680	482	1320	1210	28	56	60	2118
1100	440	590	590	710	917	730	482	1420	1310	32	56	64	2318
1200	470	630	630	765	1113	785	560	1530	1420	32	56	69	2818
1300	500	670	670	830	1130	845	642	1640	1530	32	62	72	3568
1400	530	710	710	890	1165	900	642	1755	1640	36	62	76	4018
1500	560	750	750	933	1215	960	797	1865	1750	36	62	77,5	4400
1600	600	790	790	1000	1275	1015	797	1975	1860	40	62	81	5500
1800	670	870	870	1100	1375	1125	797	2195	2070	44	70	88	9000
2000	760	950	950	1250	1585	1280	952	2425	2300	48	70	95	11500

PN40	VALVE DIMENSIONS							FLANGE DIMENSIONS (in mm)					Weight (KG)
DN	Series 13	Series 14	L	A	B	H1	H2	D	K	No of Holes	d	b	
100	127	190	190	120	275	120	230	235	190	8	22	24	42
125	140	200	200	135	285	135	230	270	220	8	26	26	60
150	140	210	210	150	320	150	264	300	250	8	26	28	65
200	152	230	230	190	380	204	264	375	320	12	30	34	140
250	165	250	250	225	405	237	264	450	385	12	33	38	225
300	178	270	270	258	407	270	299	515	450	16	33	42	300
350	190	290	290	290	449	297	299	580	510	16	36	46	377
400	216	310	310	330	542	345	434	660	585	16	39	50	492
450	222	330	330	345	570	360	434	685	610	20	39	50	633
500	229	350	350	378	597	393	482	755	670	20	42	52	773
600	267	390	390	445	659	460	482	890	795	20	48	60	1018
700	292	430	430	498	712	508	482	995	900	20	48	64	1318
800	318	470	470	570	827	585	482	1140	1030	24	56	72	2368
900	330	510	510	625	843	644	482	1250	1140	28	56	76	2618
1000	410	550	550	680	928	700	560	1360	1250	28	56	80	2895
1100	440	590	590	750	1045	770	642	1470	1380	28	56	84	4698
1200	470	630	630	825	1175	845	642	1575	1460	32	62	88	6568



HYDRAULIC

PNEUMATIC

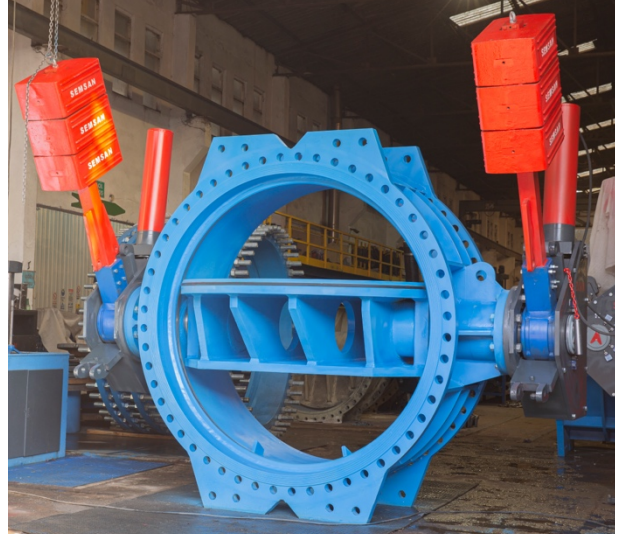

BUTTERFLY VALVE ASSEMBLY DRAWING

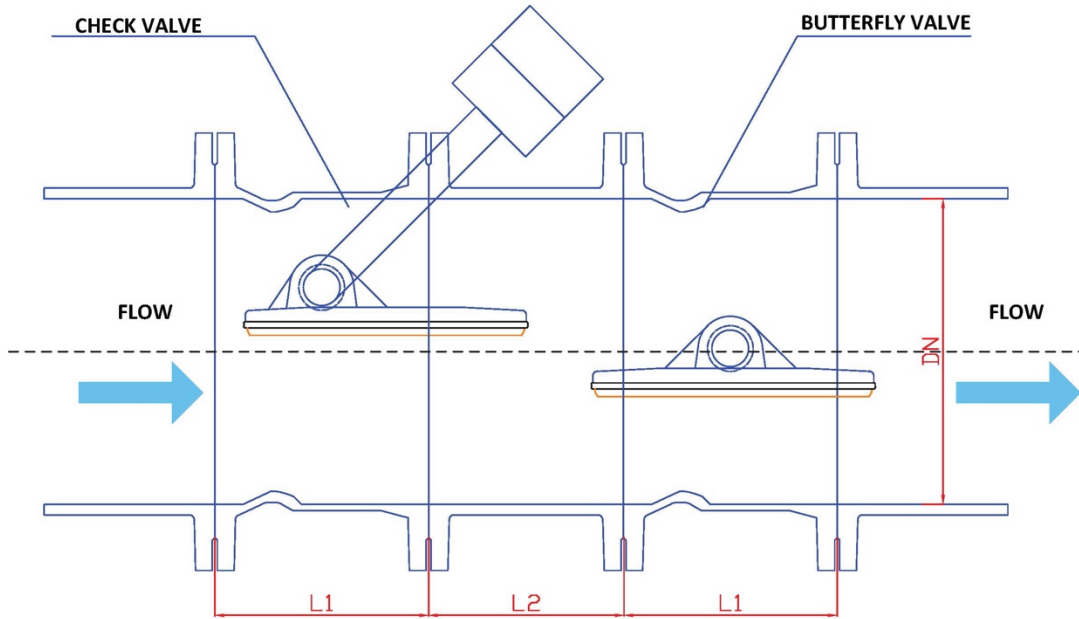

DN	L1 (mm)	L2 (mm)	L3 (mm)
150	210	150	200
200	230	150	220
250	250	150	220
300	270	150	220
350	290	225	230
400	310	225	230
450	330	300	250
500	350	300	260
600	390	400	260
700	430	500	260
800	470	600	290
900	510	650	290
1000	550	750	290
1100	590	800	300
1200	630	900	320
1300	670	1000	340
1400	710	1100	360

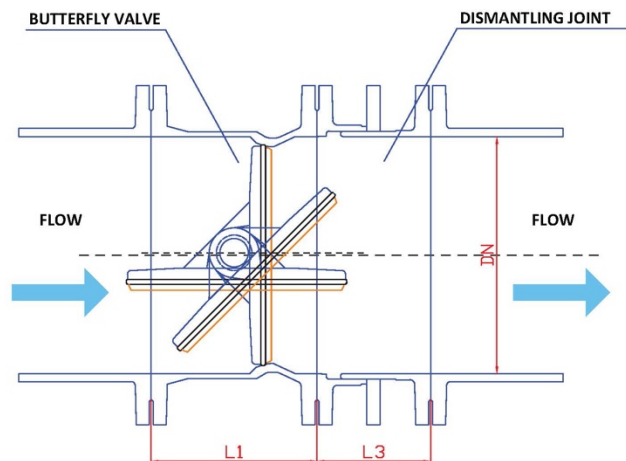

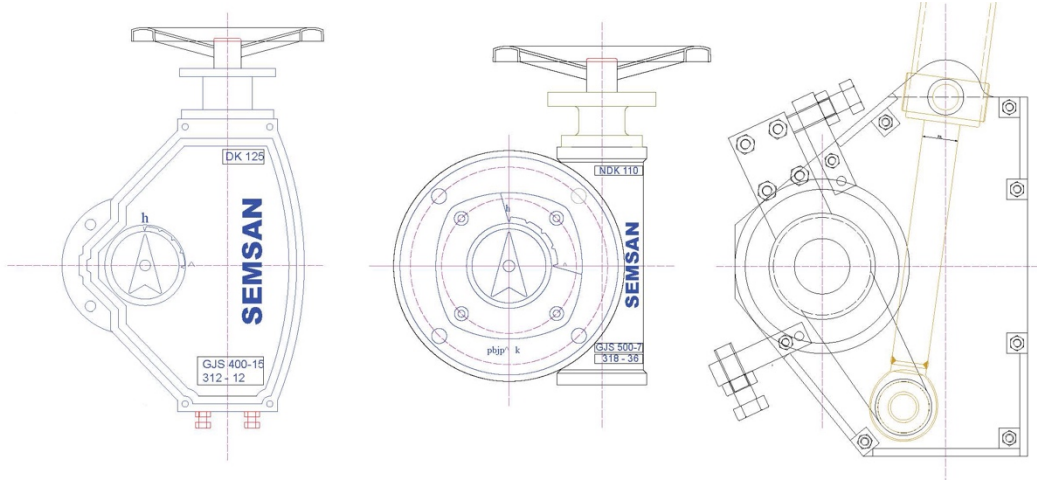

PN10	Gearbox					HYDRAULIC		PNEUMATIC
DN	MODEL	Valve connection flange(ISO 5211)	Actuator connection flange (ISO 5210)	Turn / stroke	Operation Torque (Nm)	CONTROL UNIT	Weight (kg)	UNIT
100	NDK50	F07	F07/F10 - 20 / 30 mm	10	30			RA80DA
125	NDK50	F07		10	30			RA80DA
150	NDK50	F07		10	30			RA80DA
200	NDK50	F07		10	60	HK50	85	RA120DA
250	NDK80	F12		16,5	60	HK50	101	RA120DA
300	NDK80	F12		16,5	60	HK50	121	PN1
350	NDK80	F14		16,5	60	HK50	150	PN1
400	NDK80	F14		16,5	60	HK50	169	PN1
450	NDK125	F16	F10/F14 - 20 / 30 mm	15	60	HK63	202	PN2
500	NDK125	F16		15	120	HK63	260	PN2
600	NDK125+MR3	F16	F10/F14 - 20 / 30 mm	45	120	HK100	426	PN2
700	NDK160+R3	F25		45	120	HK100	556	
800	NDK160+R3	F25		45	120	HK125	776	
900	NDK200+R9	F30	F10/F14 - 30 mm	126	120	HK125	924	
1000	NDK200+R9	F30		126	120	HK125	1188	
1100	NDK200+R12	F30		168	120	HK125	1434	
1200	NDK285+R16	F35		216	120	HK125	1640	
1300	NDK285+R25	F35		337,5	120	HK160	2260	
1400	NDK285+R36	F35		486	120	HK160	2518	
1500	NDK370+R25	F40		356	250	HK160	3355	
1600	NDK370+R25	F40		356	250	HK160B	4085	
1800	NDK370+R25	F40	F14 - 30 mm	356	250	HK160B	4920	
2000	NDK450+R36	F48		356	500	HK200	7162	
2200	NDK450+R36	F48		486	500	HK200x2	10322	
2400	NDK450+R36	F48		486	500	HK200x2	12422	

PN16	Gearbox					HYDRAULIC		PNEUMATIC	
DN	MODEL	Valve flange (ISO 5211)	Actuator flange (ISO 5210)	Turn / stroke	Operation Torque (Nm)	CONTROL UNIT	Weight (kg)	UNIT	
100	NDK50	F07	F07/F10 - 20 / 30 mm	10	30			RA80DA	
125	NDK50	F07		10	30			RA80DA	
150	NDK50	F07		10	30			RA80DA	
200	NDK80	F12		16,5	60	HK50	74	RA120DA	
250	NDK80	F12		16,5	60	HK50	101	RA120DA	
300	NDK80	F12		16,5	60	HK50	129	PN1	
350	NDK80	F14		16,5	120	HK50	150	PN2	
400	NDK125	F16	F10/F14 - 20 / 30 mm	15	120	HK50	194	PN2	
450	NDK125	F16		15	120	HK63	260	PN3	
500	NDK125	F16		15	120	HK63	320	PN3	
600	NDK125+MR3	F16	F10/F14 - 30 mm	45	120	HK100	587	PN3	
700	NDK125+R9	F25		135	120	HK100	730		
800	NDK200+R9	F30		126	120	HK125	819		
900	NDK200+R9	F30		126	120	HK125	1014		
1000	NDK200+R12	F30		168	120	HK125	1364		
1100	NDK200+R16	F30		168	120	HK125	1614		
1200	NDK285+R25	F35		337,5	120	HK160	2090		
1300	NDK285+R25	F35		337,5	250	HK160	2545		
1400	NDK370+R25	F40		356	250	HK160	2775		
1500	NDK370+R25	F40		356	250	HK160	3585		
1600	NDK370+R25	F40	F14 - 30 mm	486	250	HK160B	4320		
1800	NDK450+R36	F48		356	250	HK160B	4622		
2000	NDK450+R36	F48		486	500	HK200	7432		
PN25									
100	NDK50	F07	F07/F10 - 20 / 30 mm	10	30				
125	NDK50	F07		10	30				
150	NDK80	F12		16,5	60				
200	NDK80	F12		16,5	60	HK50	104		
250	NDK110	F16	F10/F14 - 20 / 30 mm	13	60	HK50	99		
300	NDK110	F16		13	120	HK50	149		
350	NDK110	F16		13	120	HK50	194		
400	NDK125+MR3	F16		45	120	HK50	247		
450	NDK125+MR3	F16		45	120	HK63	383		
500	NDK160+R9	F25		F10/F14 - 30 mm	135	120	HK63	382	
600	NDK160+R9	F25			135	120	HK100	615	
700	NDK200+R12	F30			168	120	HK125	964	
800	NDK200+R12	F30			168	250	HK125	1194	
900	NDK200+R16	F30			224	250	HK125	1874	
1000	NDK200+R16	F30	224		250	HK125	2144		
1100	NDK200+R16	F30	224		250	HK125	2344		
1200	NDK285+R25	F35	337,5		500	HK160	2800		
1300	NDK370+R25	F40	F14 - 30 mm		356	500	HK160	3380	
1400	NDK370+R25	F40			356	500	HK160	3830	
1500	NDK370+R36	F40		486	500	HK160B	4243		
1600	NDK450+R36	F48		356	500	HK160B	4802		
1800	NDK450+R36	F48		486	500	HK200	8982		
2000	NDK450+R36	F48		486	500	HK200x2	12522		

PN40	Gearbox					HYDRAULIC		PNEUMATIC
DN	MODEL	Valve connection flange(ISO 5211)	Actuator connection flange (ISO 5210)	Turn / stroke	Operation Torque (Nm)	CONTROL UNIT	Weight (kg)	UNIT
100	NDK80	F12	F07/F10 - 20 / 30 mm	16,5	120			
125	NDK80	F12		16,5	120			
150	NDK80	F16		13	120			
200	NDK110	F16		13	120	HK50	149	
250	NDK110	F16		13	120	HK50	234	
300	NDK110	F16		45	120	HK50	309	
350	NDK125+MR3	F16		45	120	HK50	357	
400	NDK125+MR3	F25	F10/F14 - 30 mm	135	120	HK50	472	
450	NDK125+R9	F25		135	120	HK63	587	
500	NDK160+R9	F30		168	120	HK63	687	
600	NDK160+R9	F30		168	120	HK125	1100	
700	NDK200+R12	F30	F14 - 30 mm	224	250	HK125	1344	
800	NDK200+R16	F30		224	250	HK125	2394	
900	NDK285+R25	F30		224	250	HK125	2500	
1000	NDK285+R36	F35		337,5	250	HK125	2768	
1100	NDK370+R25	F40		356	250	HK125	4410	
1200	NDK370+R25	F40		356	250	HK160	6380	

INTERNETIONAL STANDARTS FOR DESIGN		
MAIN TYPE	EN 593	Double Eccentric Double Offset
FACE TO FACE DIMENSONS	EN 558 - 1	SERIES 14 and SERIES 13
FLANGE DIMENSIONS	EN 1092	Flange norm can be revise up to customer
VALVE CONNECTION FLANGES	ISO 5211	
FINAL ACCEPTANCE TEST	EN12266 1 - 2	Rate A (Zero Leakage)
DESIGN TEST	1074 / EN 1267	
BODY AND DISC MATERIALS	EN1563 / AISI / EN 10202 / EN 10213	
SHAFT MATERIAL	EN 10088 / AISI	
BEARING MATERIALS	EN 1982	
CONTROL BOX	EN 60529	IP68
NON METALLIC MATERIAL	EN 681 - 1	SHORE 70 +-5
COATING	EN ISO 12944 / EN ISO 2409 / EN ISO 4624 (min 250 mikron - electropowder epoxy up to DN1400; DN1500 and bigger wet epoxy)	
COATING FOR SEAWATER	min 3 mm ebonite coating / Glass Flake Epoxy Coating	
CERTIFICATION	10204 3.1 (non witnessed) 10204 3.2 (witnessed) Third Party Tests Raw Material Certificates	



ADVANTAGES

- Pressure, flow rate and water level control valve
- Low operation torques on high pressure differences
- High safety coefficient design
- Linear regulation capability
- Suitable for modulating operation
- Low cavitation risk
- Metal seaing, additional EPDM seal ring
- Special outlet design for project.
- Operation types for application areas
- Low maintenance cost

APPLICATION AREAS

- Open – Close valve for high presure and flow velocity
- Pump Control Valve
- Water Level Control Valve
- Bottom Outlet Valve
- Turbine Inlet and Turbine By – Pass Valve
- Pressure Control Valve for Drinking Water
- Flow Rate Regulation Valve
- Pressure Control for Irrigation Projects

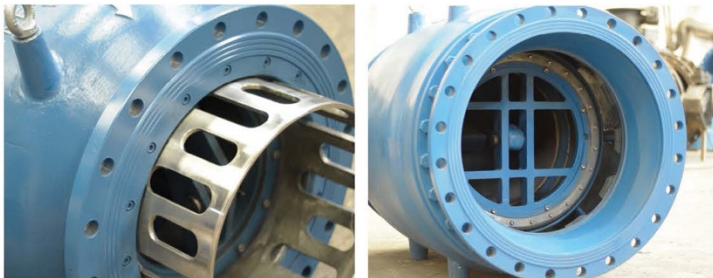

DESIGN

- TS EN 593 Certificated
- PN10 – PN64
- Double Flange
- Face to Face EN 558 – 1 Series 15 (up to DN500 1,5 x DN)
- Open Close and Control Valve
- Axial Movement for Plunger
- Rotationally Symetric Flow
- Metal seaing, additional EPDM seal ring
- Adjustable and Replaceable Sealing Ring
- Mechanical position indicator and limit stops on gear box
- Max Operation Temperature 50°C
- Movement Parts are Stainless Steel

CORROSION PROTECTION

- Electrostatic Powder Coating for Drinking Water
- Zinch – Rich Epoxy Primer
- Coal – Tar Epoxy
- Glass Flake Epoxy
- Enamel Epoxy for Ultraviolet
- Completely Stainless Steel Design
- Ebonite Coating for Seawaater

OPERATION

- Handwheel
- Electrical Actuator
- Pneumatic Actuator
- Hydraulic Actuator
- On-off or Modulating Operation



TURBINE BY-PASS VALVE PLUNGER VALVE WITH HYDRAULIC

DN 150/1400 | PN 10/ 16/ 25/ 40/ 64



DESIGN

- Flanges DIN EN 1092
- Open – close and control valve
- Circle section symmetrical flow
- Moving linear plunger
- Metal sealing, and EPDM sealing ring
- V-port for high pressure difference
- Maximum working temperature 50 °C

CONTROL

- Counterweight and hydraulic pistons help closing very fast with the provide of hydraulic piston will be closed

OPTIONAL

- Electrical actuator
- Handwheel
- DN > 1400

APPLICATION

When the turbine inlet valve closed it is using for bypass the water in penstock and save from hammer and high pressure

MATERIAL

- Body is ductile iron casting (GGG-40/50)
- Moving internal parts stainless steel AISI 304
- Valve shaft is stainless steel AISI 420
- Bearing is bronze
- Plunger seal ring EPDM

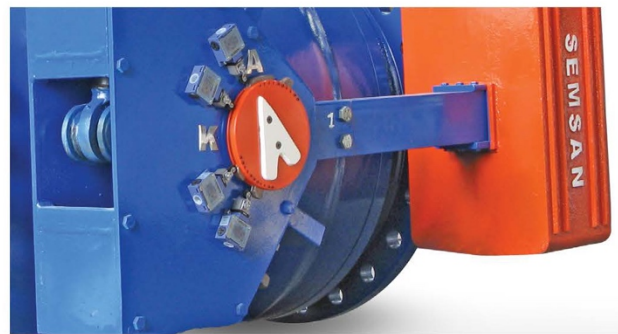

LAST QUALITY CONTROL EN 12266 – 1 CLASS A

Nominal Diameter (DN)	Nominal Pressure PN kg / cm ²	Test Pressure		Max Pressure for Temperature 50 °C
		Body	Disk	
150.....1400	10	15	15	10
150.....1400	16	24	24	16
150.....1400	25	37,5	27,5	25
150.....1400	40	60	44	40
150.....1400	64	96	71	64

* All of dimensions and explanations has been given for information. SEMSAN reserve right to keep change all them off.

INLINE REGULATION VALVE

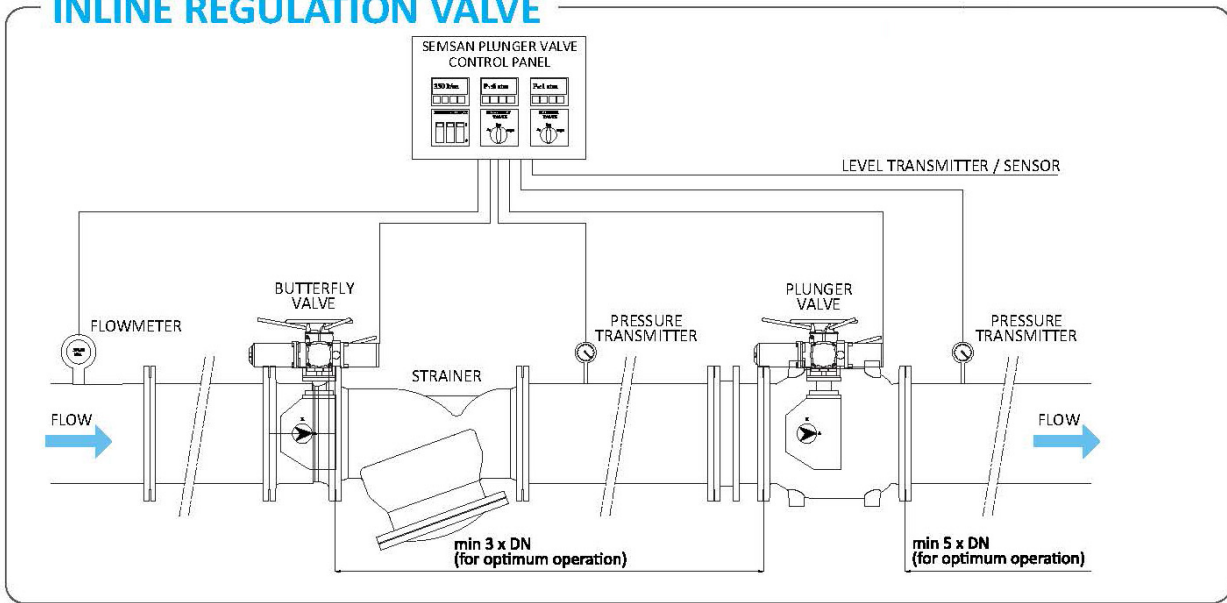

BOTTOM OUTLET DISCHARGE VALVE

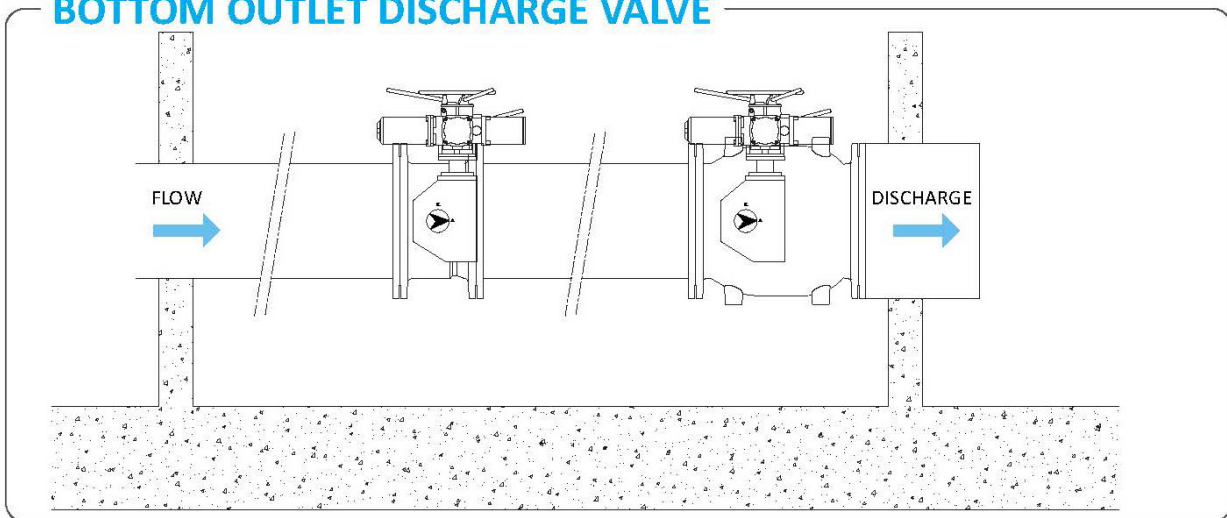

INLINE HYDROFLOW PLUNGER VALVE (WORKING WITH LINE PRESSURE)

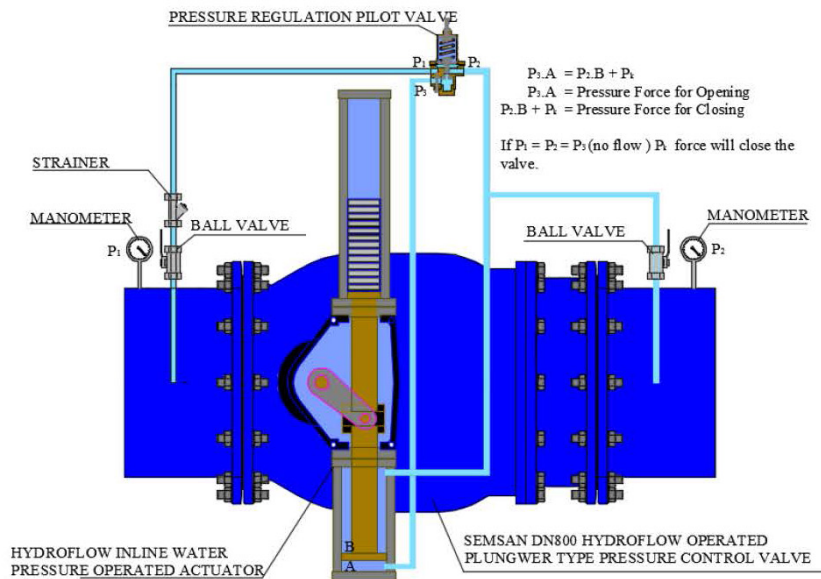

VERSIONS

PERFORATED CYLINDER

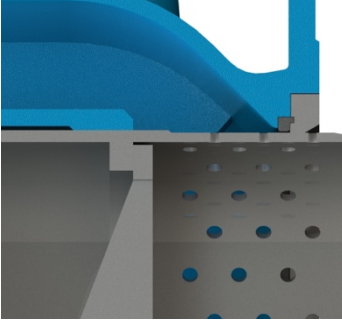

SLOTTED CYLINDER

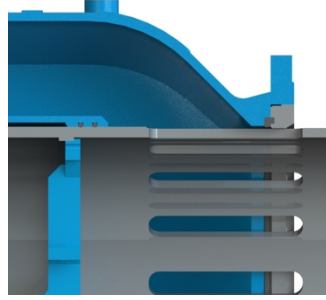

VPORT

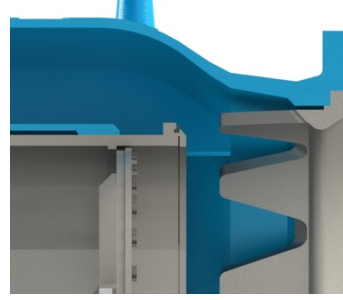

SEAT RING

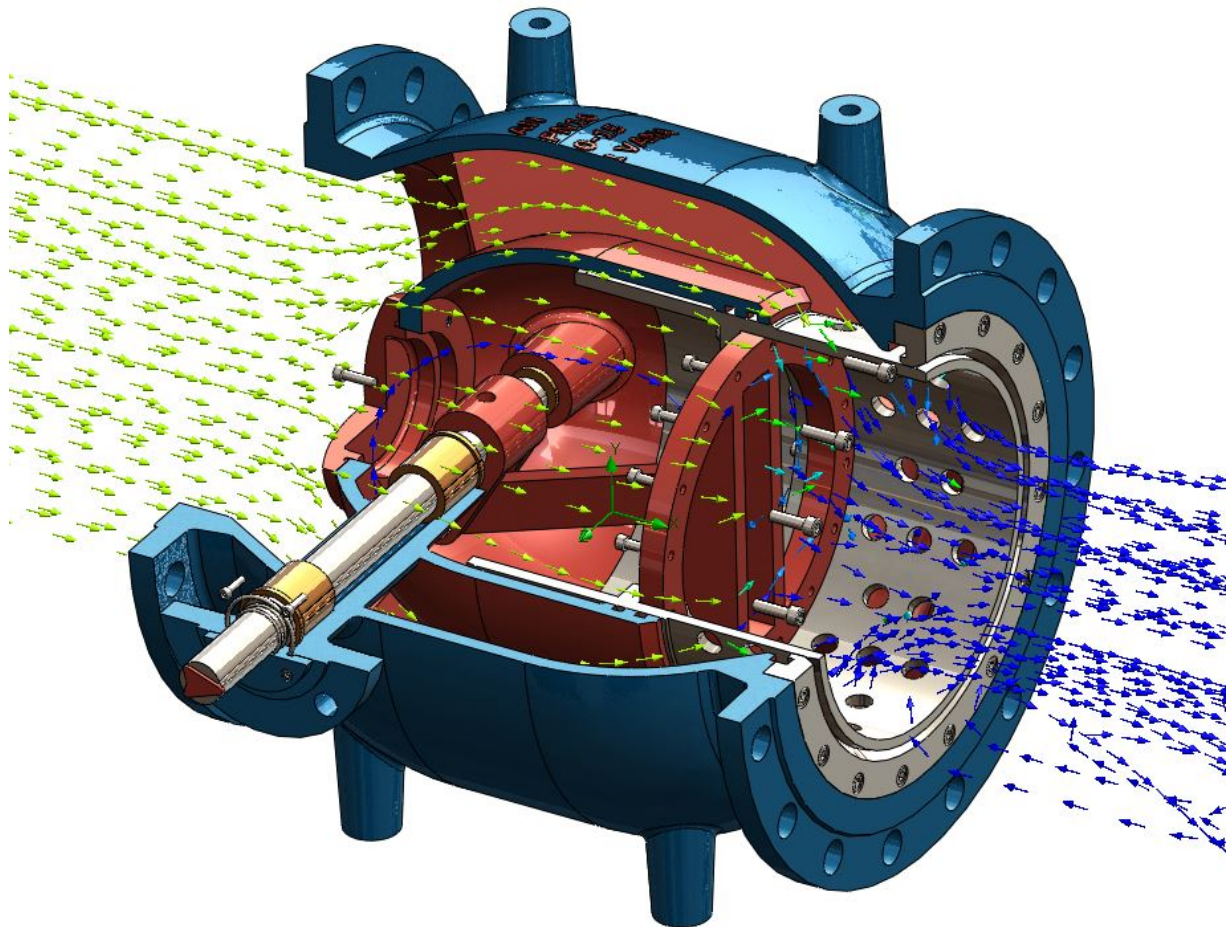
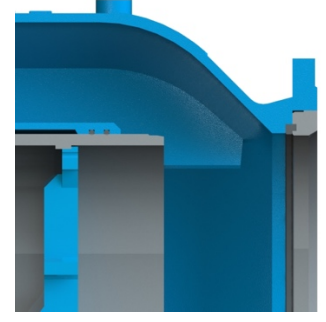

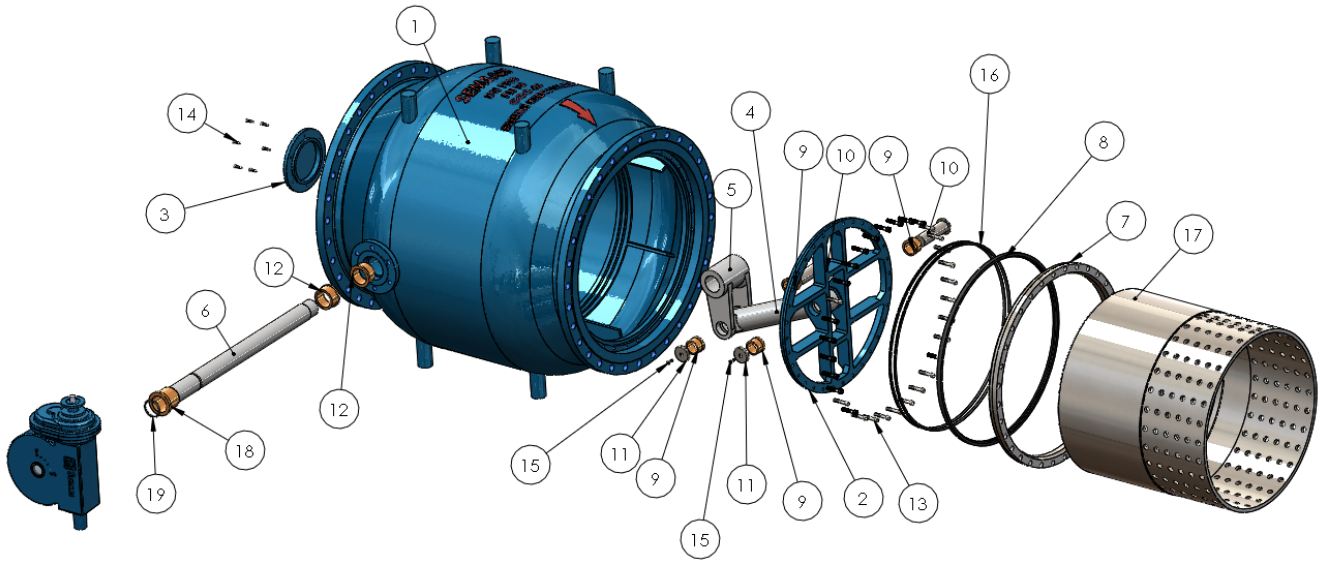

NO	PART	STANDART MATERIAL	OPTIONAL MATERIALS	
1	BODY	DUCTILE IRON		
2	PISTON CONNECTION PART	GJS400.15 / GJS400.18 /		
3	BACK LID	GJS500.7 / GJS500.14		
4	CRANK	1.4021 (AISI420)		
5	CONNECTING PART	DUCTILE IRON GJS400.15 / GJS400.18 / GJS500.7 / GJS500.14		
6	VALVE SHAFT	1.4021 (AISI420)	1.4057 (AISI431)	1.4462 (Duplex SS)
7	SEALING RING FLANGE	AISI 304	AISI 316	AISI 329 Duplex (S32900)
8	SEALING RING	EPDM	NBR	VITON
9	CRANK BEARINGS	GCuSn10	Derlin	PTFE
10	CONNECTION PINS	1.4021 (AISI420)	1.4057 (AISI431)	1.4462 (Duplex SS)
11	PINS BEARING CAP	1.4021 (AISI420)	1.4057 (AISI431)	1.4462 (Duplex SS)
12	SHAFT BEARINGS	GCuSn10	Derlin	PTFE
13	FLANGE BOLTS	A2	A4	
14	BACK LID BOLTS	A2	A4	
15	PIN BOLTS	A2	A4	
16	PISTON SEALING RINGS	EPDM	NBR	VITON
17	SHAFT BEARINGS	GCuSn10	Derlin	PTFE
18	SHAFT SEALING RINGS	EPDM	NBR	VITON
19	CONTROL BOX	SEMSAN NDK SERIES (IP68)		
20	PLUNGER PISTON	AISI 304 / AISI 304L	AISI 316 / AISI316L	DUPLEX / SUPER DUPLEX STAINLESS STEEL
21	PLUNGER BEARING SURFACE	BRONZE WELDED		
22	COATING	ELECTROPOWDER EPOXY	WET EPOXY, GLASS FLAKE	EBONITE

INTERNETIONAL STANDARTS FOR DESIGN		
MAIN TYPE	AXIAL FLOW AND PRESSURE CONTROL VALVE	
FACE TO FACE DIMENSIONS	1,5x DN	EN 558 - 1 SERIES 15 up to DN500
FLANGE DIMENSIONS	EN 1092	Flange norm can be revise up to customer
VALVE CONNECTION FLANGES	ISO 5211	
FINAL ACCEPTANCE TEST	EN12266 1 - 2	Rate A (Zero Leakage)
DESIGN TEST	1074 / EN 1267	
BODY AND DISC MATERIALS	EN1563 / AISI / EN 10202 / EN 10213	
SHAFT MATERIAL	EN 10088 / AISI	
BEARING MATERIALS	EN 1982	
CONTROL BOX	EN 60529	IP68
NON METALLIC MATERIAL	EN 681 - 1	SHORE 70 +-5
COATING	EN ISO 12944 / EN ISO 2409 / EN ISO 4624 (min 250 mikron - electropowder epoxy up to DN1400; DN1500 and bigger wet epoxy)	
COATING FOR SEAWATER	min 3 mm ebonite coating / Glass Flake Epoxy Coating	
CERTIFICATION	10204 3.1 (non witnessed) 10204 3.2 (witnessed) Third Party Tests Raw Material Certificates	



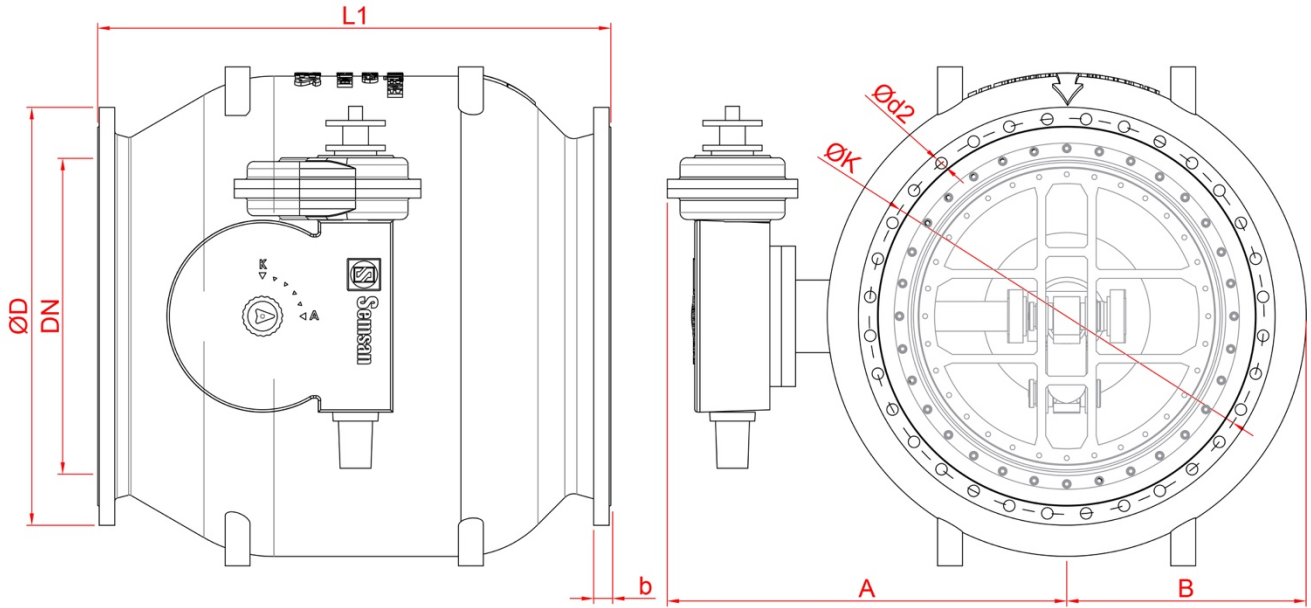

PN10										
DN	SERIES 15 (L1)	VALVE DIMENTIONS				FLANGE DIMENSIONS (in mm)				
		A	B	D	Volume	D	K	No of Holes	d2	b
100	300	225	110	220	0,02	220	180	8	19	19
125	325	240	125	250	0,03	250	210	8	19	19
150	350	305	143	285	0,04	285	240	8	23	19
200	400	335	170	340	0,06	340	295	8	23	20
250	450	350	200	400	0,07	400	350	12	23	22
300	500	365	228	455	0,09	455	400	12	23	24,5
350	550	390	255	505	0,11	505	460	16	23	24,5
400	600	515	290	565	0,15	565	515	16	28	24,5
450	600	515	310	615	0,17	615	565	20	28	25,5
500	750	550	360	670	0,2	670	620	20	28	26,5
600	900	630	435	780	0,27	780	725	20	31	30
700	1050	780	515	895	0,38	895	840	24	31	32,5
800	1200	840	565	1015	0,47	1015	950	24	34	35
900	1350	870	560	1115	0,53	1115	1050	28	34	37,5
1000	1500	1080	695	1230	0,72	1230	1160	28	37	40
1100	1500	1080	695	1340	0,78	1340	1270	32	37	43
1200	1800	1120	825	1455	0,93	1455	1380	32	41	45

PN 16										
DN	SERIES 15 (L1)	VALVE DIMENTIONS				FLANGE DIMENSIONS (in mm)				
		A	B	D	Volume	D	K	No of Holes	d	b
100	300	225	110	220	0,02	220	180	8	19	19
125	325	240	125	250	0,03	250	210	8	19	19
150	350	305	143	285	0,04	285	240	8	23	19
200	400	335	170	340	0,06	340	295	12	23	20
250	450	350	200	400	0,07	400	355	12	28	22
300	500	365	228	455	0,09	455	410	12	28	24,5
350	550	390	260	520	0,11	520	470	16	28	26,5
400	600	515	290	580	0,15	580	525	16	31	28
450	600	515	320	640	0,18	640	585	20	31	30
500	750	550	360	715	0,21	715	650	20	34	31,5
600	900	630	435	840	0,3	840	770	20	37	36
700	1050	780	515	910	0,39	910	840	24	37	39,5
800	1200	840	565	1025	0,48	1025	950	24	40	43
900	1350	870	565	1125	0,53	1125	1050	28	40	46,5
1000	1500	1080	695	1255	0,74	1255	1170	28	43	50
1100	1500	1080	680	1355	0,79	1355	1270	32	43	53,5
1200	1800	1120	825	1485	0,95	1485	1390	32	49	57
PN 25										
100	300	225	120	235	0,03	220	180	8	19	19
125	325	240	135	270	0,03	270	220	8	28	19
150	350	305	150	300	0,05	300	250	8	28	20
200	400	335	180	360	0,06	360	310	12	28	22
250	450	350	115	425	0,07	425	370	12	31	24,5
300	500	365	245	485	0,1	485	430	16	31	27,5
350	550	390	280	555	0,12	555	490	16	34	30
400	600	575	310	620	0,18	620	550	16	37	32
450	600	575	335	670	0,2	670	600	20	37	34,5
500	750	610	365	730	0,23	730	660	20	37	36,5
600	900	740	435	845	0,33	845	770	20	40	42
700	1050	840	515	960	0,43	960	875	24	43	46,5
800	1200	840	565	1085	0,5	1085	990	24	49	51
900	1350	870	595	1185	0,57	1185	1090	28	49	55,5
1000	1500	1090	695	1320	0,78	1320	1210	28	56	60
1100	1500	1090	710	1420	0,84	1420	1310	32	56	64
1200	1800	1130	825	1530	0,99	1530	1420	32	56	69

DN	PN10			
	GEARBOX	PNEUMATIC	Operation Torque (Nm)	HYDRAULIC
100	NDK50	RA80DA	30	
125	NDK50	RA80DA	30	
150	NDK50	RA80DA	30	
200	NDK80	RA120DA	30	HK50 + 80
250	NDK80	RA120DA	60	HK50 + 80
300	NDK80	PN1	60	HK50 + 160
350	NDK110	PN1	60	HK50 + 160
400	NDK125	PN1	60	HK50 + 280
450	NDK125	PN2	60	HK63 + 280
500	NDK125+MR3	PN2	60	HK63 + 280
600	NDK125+MR3	PN2	60	HK63 + 550
700	NDK160+R9		120	HK63 + 550
800	NDK160+R9		120	HK100 + 550
900	NDK200+R9		120	HK100 + 550
1000	NDK200+R9		120	HK125 + 550
1100	NDK200+R9		120	HK125 + 1100
1200	NDK200+R9		120	HK125 + 1100
1300	NDK285+R16		120	HK125 + 1650
1400	NDK285+R16		120	HK125 + 1650
1500	NDK370+R25		250	HK160 + 1650
1600	NDK370+R25		250	HK160 + 1650

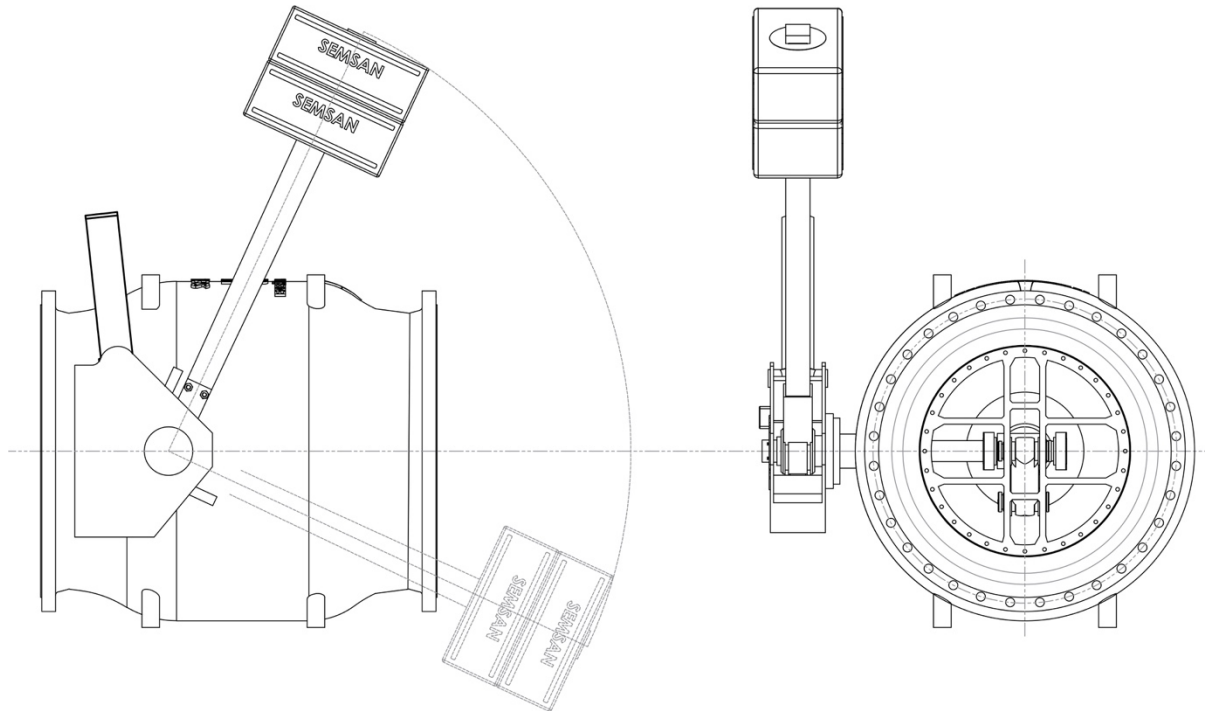

DN	PN16			
	GEARBOX	PNEUMATIC	Operation Torque (Nm)	HYDRAULIC
100	NDK50	RA80DA	30	
125	NDK50	RA80DA	30	
150	NDK50	RA80DA	30	
200	NDK80	RA120DA	30	HK50 + 80
250	NDK80	RA120DA	60	HK50 + 80
300	NDK80	PN1	60	HK50 + 160
350	NDK110	PN1	60	HK50 + 160
400	NDK125	PN1	60	HK50 + 280
450	NDK125	PN2	60	HK63 + 280
500	NDK125	PN2	60	HK63 + 280
600	NDK125	PN2	60	HK63 + 550
700	NDK160+R9		120	HK63 + 550
800	NDK160+R9		120	HK100 + 550
900	NDK200+R9		120	HK100 + 550
1000	NDK200+R9		120	HK125 + 550
1100	NDK200+R9		120	HK125 + 1100
1200	NDK200+R9		120	HK125 + 1100
1300	NDK285+R16		120	HK125 + 1650
1400	NDK285+R16		120	HK125 + 1650
1500	NDK370+R25		250	HK160 + 1650
1600	NDK370+R25		250	HK160 + 1650
PN25				
100	NDK50	RA80DA	30	
125	NDK50	RA80DA	30	
150	NDK80	RA80DA	30	
200	NDK80	RA120DA	60	HK50 + 80
250	NDK110	RA120DA	60	HK50 + 80
300	NDK125	PN1	60	HK50 + 160
350	NDK125	PN1	60	HK63 + 160
400	NDK125	PN1	60	HK63 + 280
450	NDK125	PN2	60	HK63 + 280
500	NDK125+MR3	PN2	60	HK63 + 280
600	NDK125+R9	PN2	60	HK100 + 550
700	NDK160+R9		120	HK100 + 550
800	NDK160+R9		120	HK125 + 550
900	NDK200+R9		120	HK125 + 550
1000	NDK200+R9		120	HK125 + 550
1100	NDK285+R16		120	HK125 + 1100
1200	NDK285+R16		120	HK125 + 1100
1300	NDK370+R25		120	HK160 + 1650
1400	NDK370+R25		250	HK160 + 1650

Y-TYPE STRAINER

DN 150/600 | PN 10/ 16/ 25



APPLICATION

- Entrance of control valves
- Drinking water treatment plants

DESIGN

- Body is 65° horizontal to flow
- Flanges DIN EN1092
- PN 10/16/25
- Perforated filter is stainless steel
- There is a plug for cleaning residuals dirty on the filter

MATERIAL

- Body ductile iron GGG-40/50
- Filter is stainless steel
- Flange connection bolts are galvanized steel

OPTIONAL

- DN > 600
- Manometers are input and output of strainer
- Discharge valve on blind flanges
- All of body stainless steel

CORROSION PROTECTION

- Electrostatic Powder Coating for Drinking Water
- Zinch – Rich Epoxy Primer
- Coal – Tar Epoxy
- Glass Flake Epoxy
- Enamel Epoxy for Ultraviolet
- Completely Stainless Steel Design
- Ebonite Coating for Seawaater

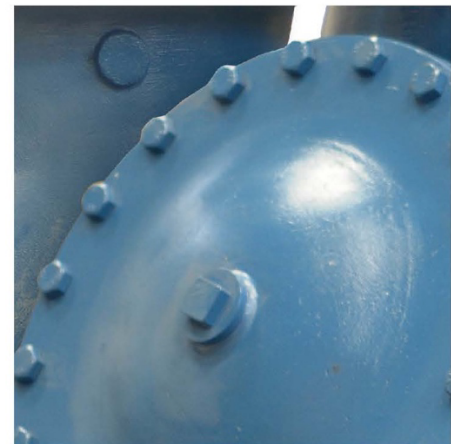

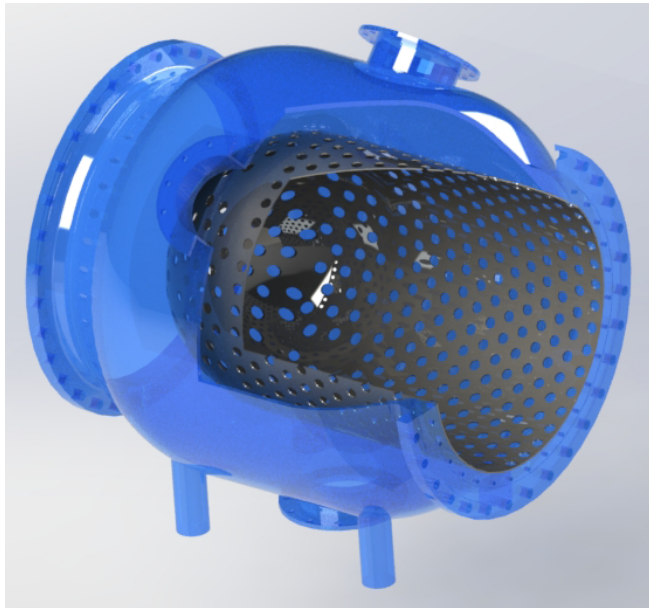

APPLICATION

- Before Control Valve
- In Water Treatment Plant

DESIGN

- Designed In Parallel With The Flow
- Flanges DIN EN 1092
- Suitable For PN 10/16/25
- Stainless Steel Perforated Filter
- Filter Without Removing The Valve Or Line , Allowing Clear All The Accumulated Sediment
- Compact Design
- Two Input For Clean Water Filter Cleaning
- Sewage Outlet Cover Under Valve

MATERIAL

- Body Ductile Iron GGG-40/50
- Filter Is Stainless Steel
- Flange Connection Bolts Are Galvanized Steel

CORROSION PROTECTION

- Electrostatic Powder Coating For Drinking Water
- Zinch – Rich Epoxy Primer
- Coal – Tar Epoxy
- Glass Flake Epoxy
- Enamel Epoxy For Ultraviolet
- Completely Stainless Steel Design
- Ebonite Coating For Seawater

OPTIONAL

- DN > 1400
- Manometers Are Input And Output Of Strainer
- Discharge Valve On Blind Flanges
- All Of Body Stainless Steel

LAST QUALITY CONTROL EN 12266 – 1 CLASS A

Nominal Diameter (DN)	Nominal Pressure	Test Pressure	Max Pressure	
	PN		for Temperature	
	kg/cm ²	Body	Disk	50 °C
800.....1200	10	15	-	10
800.....1200	16	24	-	16
800.....1200	25	37,5	-	25

APPLICATION

- Before Control Valve
- In Water Treatment Plant

DESIGN

- Axial Design
- Flanges DIN EN 1092
- Stainless Steel Strainer

MATERIAL

- Body EN S235JR
- Strainer AISI304
- Blind Flange nuts and bolts A2.70

CORROSION PROTECTION

- Electropowder Epoxy for Potable Water
- Zinch – Rich Epoxy Coating (Opt.)
- Coal – Tar Enamel Epoxy (Opt.)
- Ebonite Coating for seawater (Opt.)

OPTIONAL

- Manometers
- Completely Stainless Steel Design

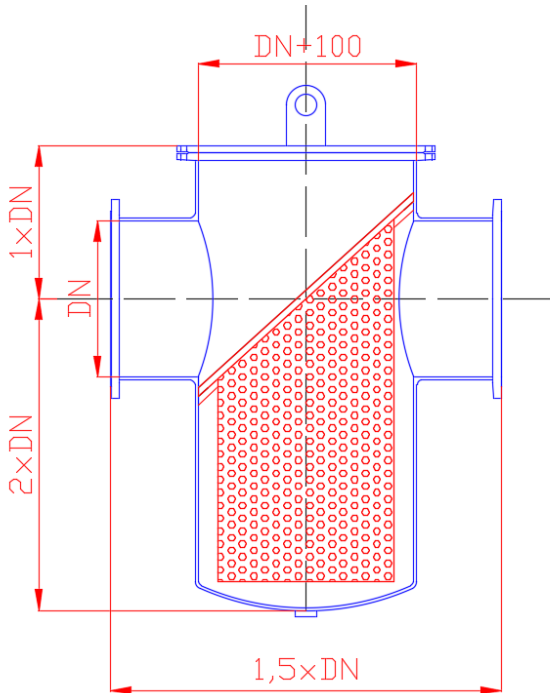

INTERNETIONAL STANDARTS FOR DESIGN	
FLANGE DIMENSIONS	EN 1092
FINAL ACCEPTANCE TEST	EN12266 1 - 2
DESIGN TEST	1074 / EN 1267
BODY AND DISC MATERIALS	EN1563 / AISI / EN 10202 / EN 10213
SHAFT MATERIAL	EN 10088 / AISI
BEARING MATERIALS	EN 1982
COATING	EN ISO 12944 / EN ISO 2409 / EN ISO 4624 (min 250 mikron - electropowder epoxy up to DN1400; DN1500 and bigger wet epoxy)
COATING FOR SEAWATER	min 3 mm ebonite coating / Glass Flake Epoxy Coating
CERTIFICATION	10204 3.1 (non witnessed) 10204 3.2 (witnessed) Third Party Tests Raw Material Certificates

TESTS	
LEAKAGE TEST	1.1 x PN
BODY TEST	1,5 X PN
COATING THICKNESS TEST	min 250 mikron
OPERATIONAL TEST	CLOSING TEST
MATERIAL TESTS	MECHANICAL, CHEMICAL, MICROSTRUCTURE



KNIFE GATE VALVE

DN 50/1200

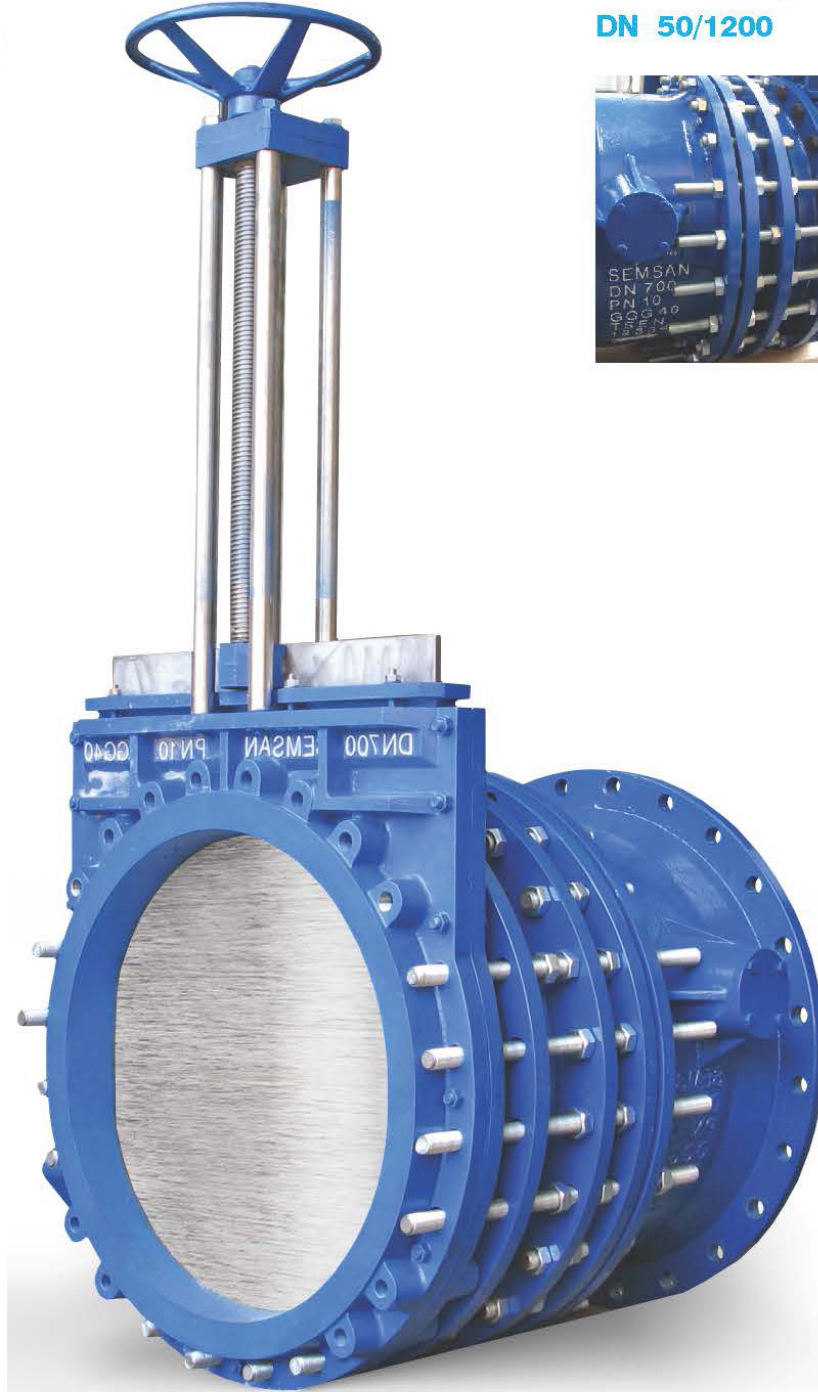

DESIGN

- Face to Face Dimensions TS EN 558 – 1 Series 20 /(DIN3202 / K1)
- Flanges TS EN 1092 – 2, PN10
- Wafer Type
- Non Rising Design
- Hand operated

OPTIONAL

- Electrical Control
- Pneumatic Control
- Hydraulic Control

MATERIAL

- Body : GJS 400-15
- Sliding (Knife) : Stainless Steel 1.4301
- Selaing : U and Horizontal EPDM

CONTROL

- Hand Operated
- Electrical Motor Controlled
- Pneumatic or Hydraulic Controlled

CORROSION PROTECTION

- Electrostatic Powder Coating for Drinking Water
- Zinc – Rich Epoxy Primer
- Coal – Tar Epoxy
- Glass Flake Epoxy
- Enamel Epoxy for Ultraviolet
- Completely Stainless Steel Design
- Ebonite Coating for Seawaater

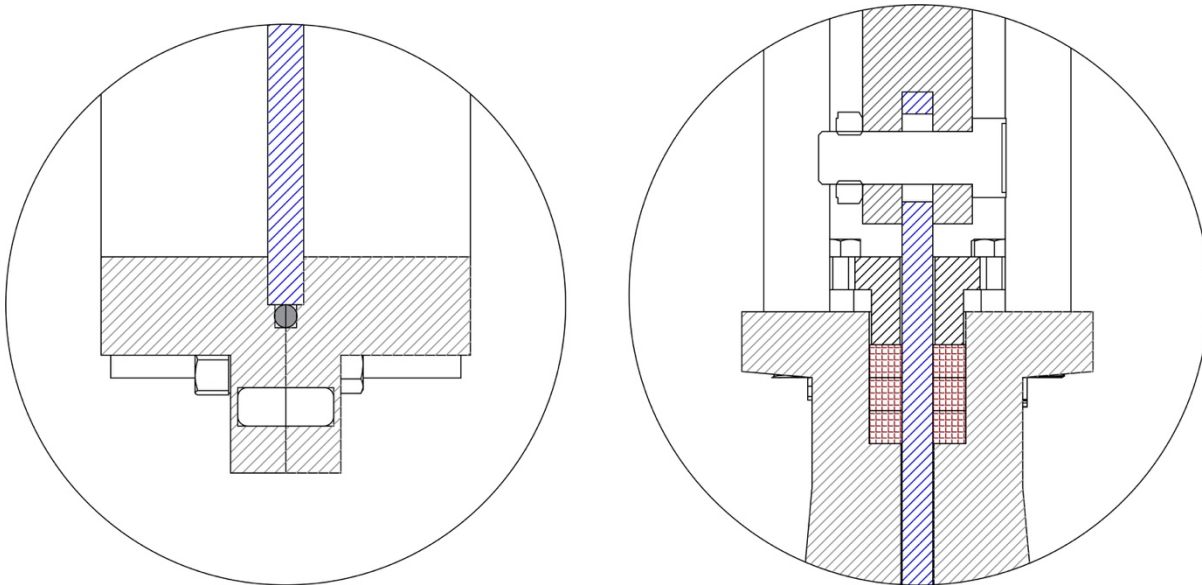
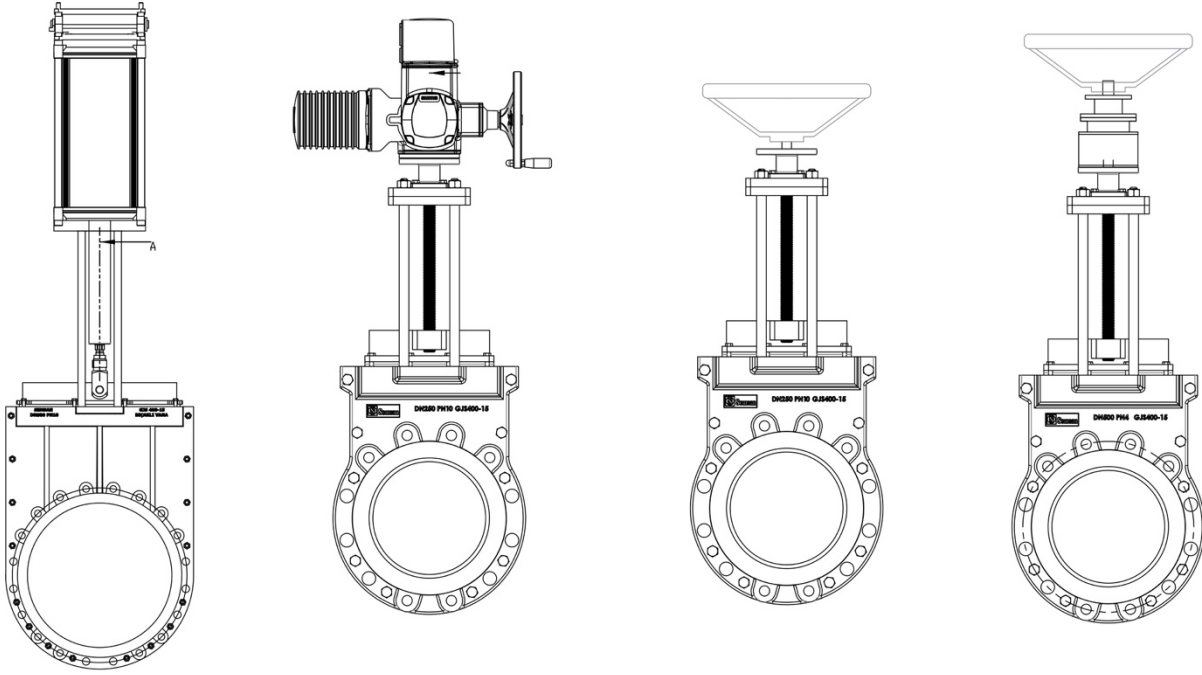

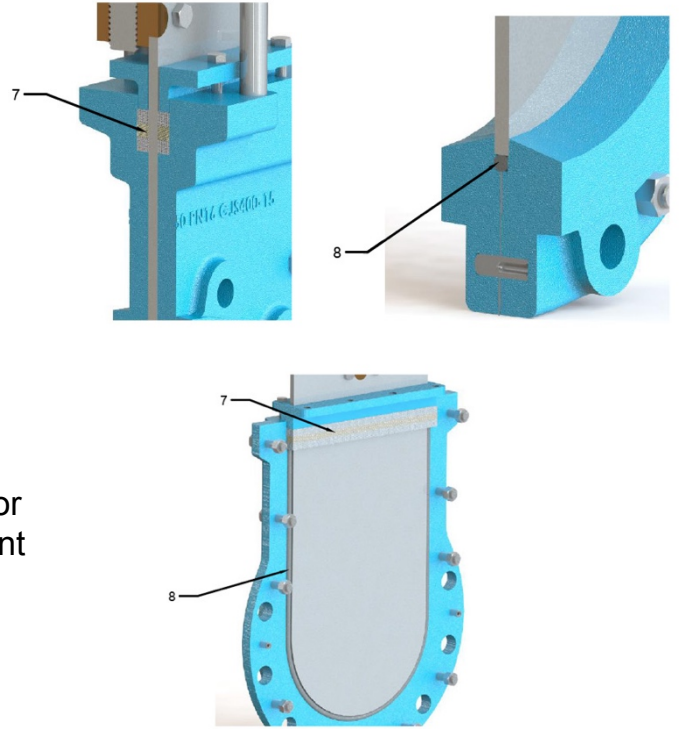
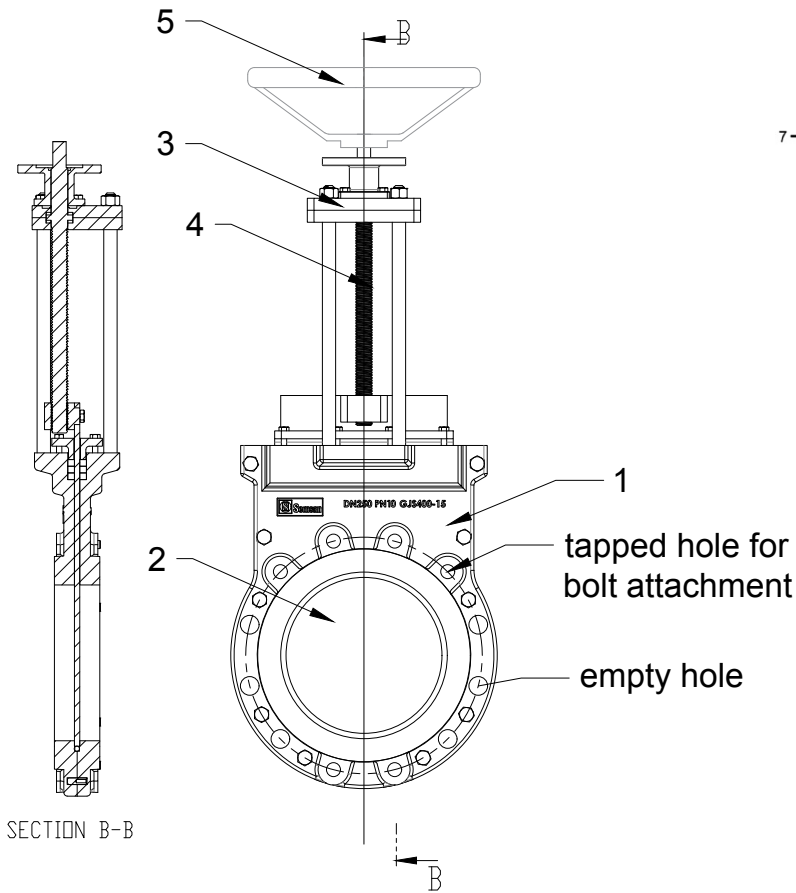

NO	PART NAME	MATERIAL
1	BODY	GJS 400.15/GJS 400.18/GJS 500.7
2	DISC	AISI 304/AISI316 SS
3	CONTROL BODY	GJS 400.15/GJS 400.18/GJS 500.7
4	ACTUATOR CONNECTION PART	AISI 420 SS
5	VOLAN	GJS 400.15/GJS 400.18/GJS 500.7
6	BOLTS AND NUTS	A2 SS
7	SEALING	SOFT SEALING
8	ORINGS	EPDM

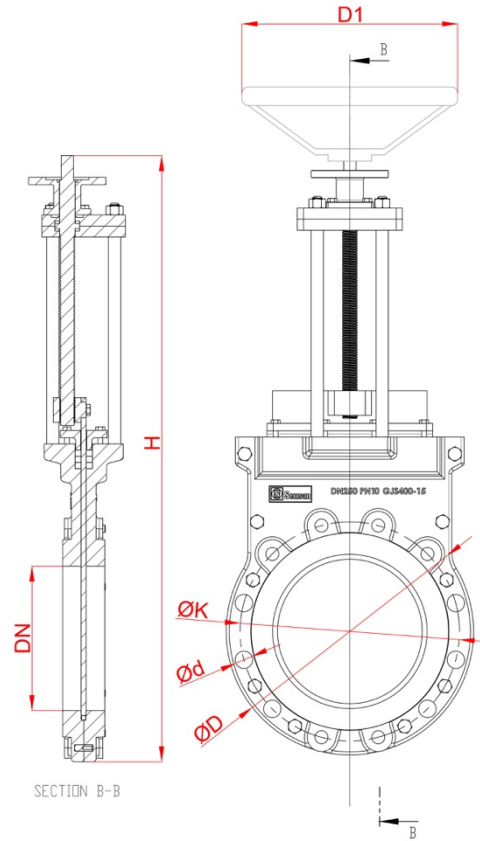

VALVE DIMENTIONS										FLANGE DIMENTIONS		
DN	L	No. of Holes	No. of Empty Holes	No. of Tapped Holes	Guide Tapped	H	D1	Turn	Suitable actu. torque	D	K	d
50	43	4	2	2 / M16	10	400	200	11	60 Nm	165	125	19
65	46	4	2	2 / M16	10	450	200	14	60 Nm	185	145	19
80	46	8	4	2 / M16	10	500	200	17	60 Nm	200	160	19
100	52	8	4	4 / M16	12	540	225	21	60 Nm	220	180	19
125	56	8	4	4 / M16	12	640	225	26	60 Nm	250	210	19
150	56	8	4	4 / M20	12	770	250	32	60 Nm	285	240	23
200	60	8	4	4 / M20	12	890	320	42	60 Nm	340	295	23
250	68	12	6	6 / M20	15	990	320	52	60 Nm	400	350	23
300	78	12	6	6 / M20	18	1110	400	52	120 Nm	455	400	23
350	78	16	6	10 / M20	18	1270	400	60	120 Nm	505	460	23
400	102	16	6	10 / M24	25	1450	400	67	120 Nm	565	515	28
450	114	20	8	12 / M24	30	1560	400	78	120 Nm	615	565	28
500	127	20	8	12 / M24	30	1900	500	221	120 Nm	670	620	28
600	154	20	8	12 / M27	40	2160	500	266	120 Nm	780	725	31
700	165	24	12	12 / M27	50	2410	500	300	250 Nm	895	840	31
800	190	24	10	14 / M30	50	2685	500	308	250 Nm	1015	950	34
900	203	28	10	18 / M30	50	3145	500	465	250 Nm	1115	1050	34
1000	216	28	10	18 / M33	60	3350	500	618	500 Nm	1230	1160	37
1200	254	32	12	20 / M36	60	3915	500	738	500 Nm	1455	1380	40

DISMANTLING JOINT

DN 80/2800 | PN 10/ 16/ 25/ 40/ 64

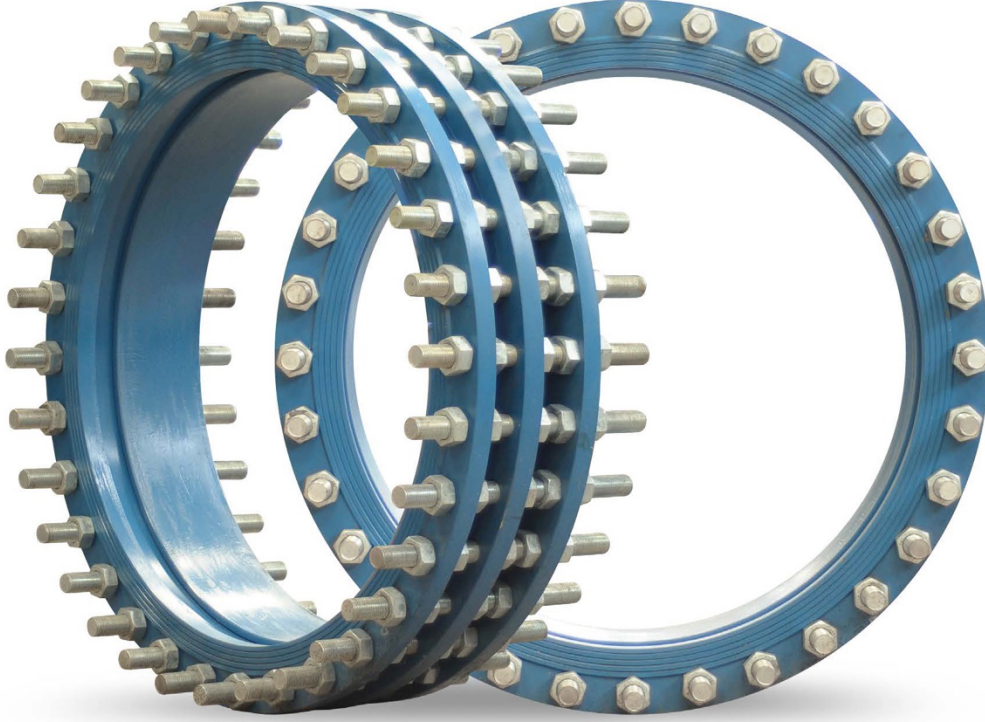

DESIGN

- TS K 461
- Flanges according to DIN EN1092
- Easily fixing to valves
- Three parts body design
- Movement Capability ± 25 mm
- Maximum operating temperature 50°C

MATERIAL

- Body ductile iron GGG 40/50
- EPDM sealing ring
- Galvanized bolts and nuts

OPTIONAL

- DN > 2800
- Stainless steel body parts
- Bolts and nuts are stainless steel

CORROSION PROTECTION

- Electrostatic Powder Coating for Drinking Water
- Zinch – Rich Epoxy Primer
- Coal – Tar Epoxy
- Glass Flake Epoxy
- Enamel Epoxy for Ultraviolet
- Completely Stainless Steel Design
- Ebonite Coating for Seawaater

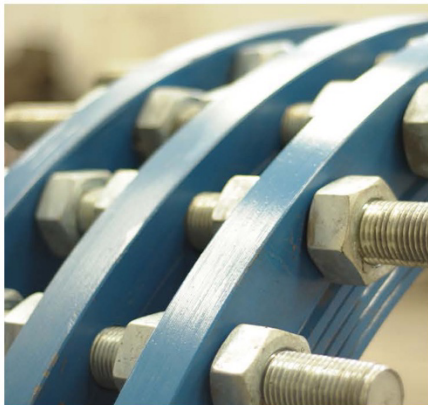

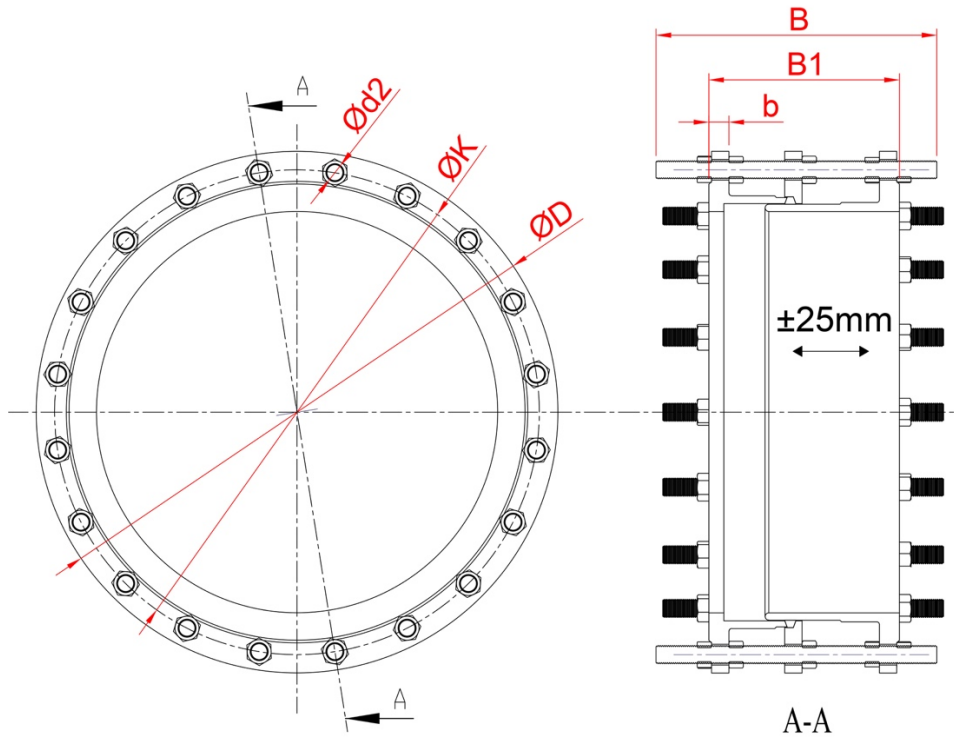

PN 10									
DN	BODY DIMENTIONS					FLANGE DIMENTIONS			
	B	Bolt Size	B	No. of Holes	KG	D	k	d2	b
100	200,00	M16	330	8	21,86	220	180	19	19
125	200,00	M16	330	8	25,65	250	210	19	19
150	200,00	M20	330	8	33,83	285	240	23	19
200	220,00	M20	330	8	45,73	340	295	23	20
250	220,00	M20	330	12	63,71	400	350	23	22
300	220,00	M20	330	12	79,30	455	400	23	24,5
350	230,00	M20	330	16	93,27	505	460	23	24,5
400	230,00	M24	380	16	118,95	565	515	28	24,5
450	260,00	M24	390	20	151,31	615	565	28	25,5
500	260,00	M24	390	20	166,15	670	620	28	26,5
600	260,00	M27	410	20	226,14	780	725	31	30
700	260,00	M27	410	24	300,52	895	840	31	32,5
800	290,00	M30	460	24	403,40	1015	950	34	35
900	290,00	M30	460	28	478,98	1115	1050	34	37,5
1000	290,00	M33	460	28	595,64	1230	1160	37	40
1100	300,00	M33	500	32	740,31	1340	1270	37	43
1200	320,00	M36	500	32	888,74	1455	1380	41	45
1300	340,00	M39	560	32	1074,84	1570	1490	44	45
1400	360,00	M39	560	36	1199,71	1675	1590	44	46
1500	380,00	M39	600	40	1428,63	1785	1700	44	47,5
1600	400,00	M45	600	40	1738,93	1915	1820	50	49
1800	400,00	M45	640	44	2058,71	2115	2020	50	52
2000	450,00	M45	650	48	2471,68	2325	2230	50	55
2200	450,00	M52	680	52	3239,59	2550	2440	56	59
2400	500,00	M52	720	56	3782,42	2760	2650	56	62

PN 16									
DN	BODY DIMENTIONS					FLANGE DIMENTIONS			
	B	Bolt Size	B	No. of Holes	KG	D	k	d2	b
100	200,00	M16	330	8	21,86	220	180	19	19
125	200,00	M16	330	8	25,65	250	210	19	19
150	200,00	M20	330	8	36,54	285	240	23	19
200	220,00	M20	330	12	49,74	340	295	23	20
250	220,00	M24	330	12	69,91	400	355	28	22
300	220,00	M24	330	12	85,41	455	410	28	24,5
350	230,00	M24	330	16	103,55	520	470	28	26,5
400	230,00	M27	380	16	146,86	580	525	31	28
450	260,00	M27	390	20	196,60	640	585	31	30
500	260,00	M30	390	20	244,15	715	650	34	31,5
600	260,00	M33	410	20	344,51	840	770	37	36
700	260,00	M33	410	24	390,00	910	840	37	39,5
800	290,00	M36	460	24	515,69	1025	950	40	43
900	290,00	M36	460	28	613,96	1125	1050	40	46,5
1000	290,00	M39	460	28	798,65	1255	1170	43	50
1100	300,00	M45	500	32	1021,52	1355	1270	43	53,5
1200	320,00	M45	500	32	1260,45	1485	1390	49	57
1300	340,00	M45	560	36	1468,65	1585	1490	49	58
1400	360,00	M45	560	36	1607,62	1685	1590	49	60
1500	380,00	M52	600	40	2140,70	1820	1710	57	62,5
1600	400,00	M52	600	40	2305,23	1930	1820	57	65
1800	400,00	M52	640	44	2741,15	2130	2020	57	70
2000	450,00	M56	650	48	3434,51	2345	2230	62	75
PN 25									
100	220,00	M20	330	8	32,63	220	180	19	19
125	220,00	M24	330	8	43,17	270	220	28	19
150	220,00	M24	330	8	48,80	300	250	28	20
200	242,00	M24	390	12	72,94	360	310	28	22
250	242,00	M27	390	12	97,66	425	370	31	24,5
300	242,00	M27	390	16	129,87	485	430	31	27,5
350	253,00	M30	410	16	174,60	555	490	34	30
400	253,00	M33	410	16	218,84	620	550	37	32
450	286,00	M33	460	20	286,14	670	600	37	34,5
500	286,00	M33	460	20	315,57	730	660	37	36,5
600	286,00	M36	460	20	426,76	845	770	40	42
700	286,00	M39	460	24	583,90	960	875	43	46,5
800	319,00	M45	500	24	809,78	1085	990	49	51
900	319,00	M45	500	28	962,50	1185	1090	49	55,5
1000	319,00	M52	500	28	1292,99	1320	1210	56	60
1100	330,00	M52	560	32	1602,84	1420	1310	56	64
1200	352,00	M52	560	32	1774,70	1530	1420	56	69
1300	374,00	M56	560	36	2171,25	1640	1530	62	72
1400	396,00	M56	650	36	2470,81	1755	1640	62	76
1500	418,00	M56	650	40	2791,55	1865	1750	62	77,5
1600	440,00	M56	650	40	3082,68	1975	1860	62	81
1800	440,00	M64	650	44	3951,47	2195	2070	70	88
2000	495,00	M64	720	48	4991,48	2425	2300	70	95

PN 40									
DN	BODY DIMENTIONS					FLANGE DIMENTIONS			
	B	Bolt Size	B	No. of Holes	KG	D	k	d2	b
100	242,00	M20	390	8	37,99	235	190	22	24
125	242,00	M24	390	8	49,93	270	220	26	26
150	242,00	M24	390	8	59,40	300	250	26	28
200	266,20	M27	460	12	108,72	375	320	30	34
250	266,20	M33	460	12	169,87	450	385	33	38
300	266,20	M33	460	16	229,19	515	450	33	42
350	278,30	M33	460	16	293,60	580	510	36	46
400	278,30	M36	460	16	386,90	660	585	39	50
450	314,60	M36	500	20	446,71	685	610	39	50
500	314,60	M39	500	20	529,07	755	670	42	52
600	314,60	M45	500	20	753,77	890	795	48	60
700	314,60	M45	500	20	1013,89	995	900	48	64
800	350,90	M52	560	24	1292,78	1140	1030	56	72
900	350,90	M52	560	28	1550,93	1250	1140	56	76
1000	350,90	M52	560	28	1804,37	1360	1250	56	80
1100	363,00	M52	560	28	2132,22	1470	1380	56	84
1200	387,20	M56	560	32	2381,85	1575	1460	62	88

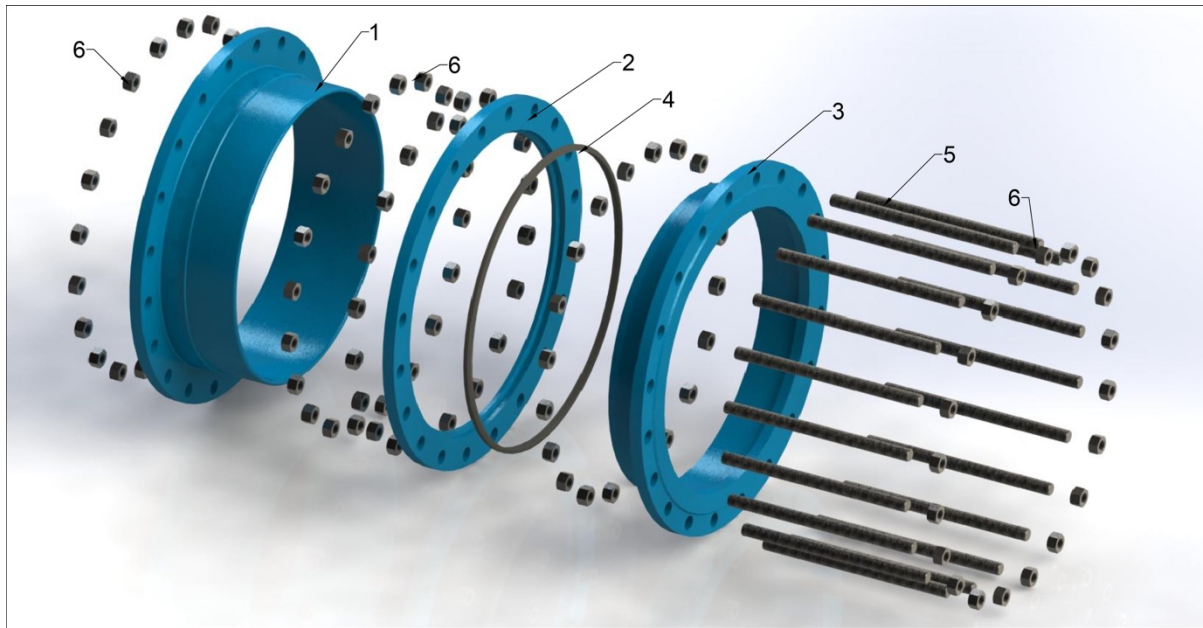

NO	PART	MATERIAL
1	Long Part	Ductile Iron / Stainless Steel
2	Retaining Ring	Ductile Iron / Stainless Steel
3	Short Part	Ductile Iron / Stainless Steel
4	Sealing Ring	NBR
5	Bolts	Galvanised / Stainless Steel
6	Nuts	Galvanised / Stainless Steel

SWING CHECK VALVE

DN 40/1000 | PN 10/ 16



DESIGN

- TS EN 12334
- Flanges DIN EN1092 - PN 10/16 Norms
- Face to face EN558-1 series 48 (2DN+100)
- Maximum operating temperature 50 °C

MATERIAL

- Body and disk ductile iron GGG 40/50
- Valve shaft stainless steel AISI 420
- Shaft bearing is bronze

CONTROL

- Closing with hydraulic damper
- Working with counterweight and without counterweight

OPTIONAL

- DN > 1000
- PN > 16
- Stainless steel disk and body
- Adjustable and replaceable EPDM sealing ring

CORROSION PROTECTION

- Electrostatic Powder Coating for Drinking Water
- Zinch – Rich Epoxy Primer
- Coal – Tar Epoxy
- Glass Flake Epoxy
- Enamel Epoxy for Ultraviolet
- Completely Stainless Steel Design
- Ebonite Coating for Seawater



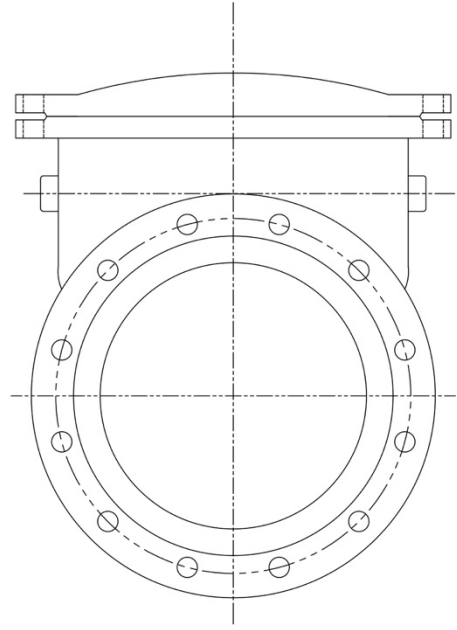
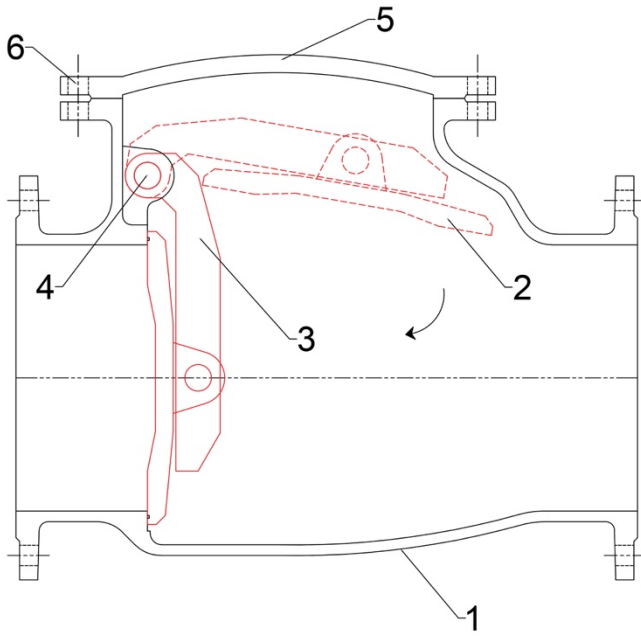

NO	PART NAME	MATERIAL
1	BODY	GJS 400.15/GJS 500.7/AISI3104/AISI316
2	DISC	GJS 400.15/GJS 500.7/AISI3104/AISI316
3	DISC HANDLE	GJS 400.15/GJS 500.7/AISI3104/AISI316
4	SHAFT	AISI 420 Stainless Steel
5	BODY TOP COVER	GJS 400.15/GJS 500.7/AISI3104/AISI316
6	BOLTS AND NUTS	A2 Stainless Steel
7	BEARING	BRONZE

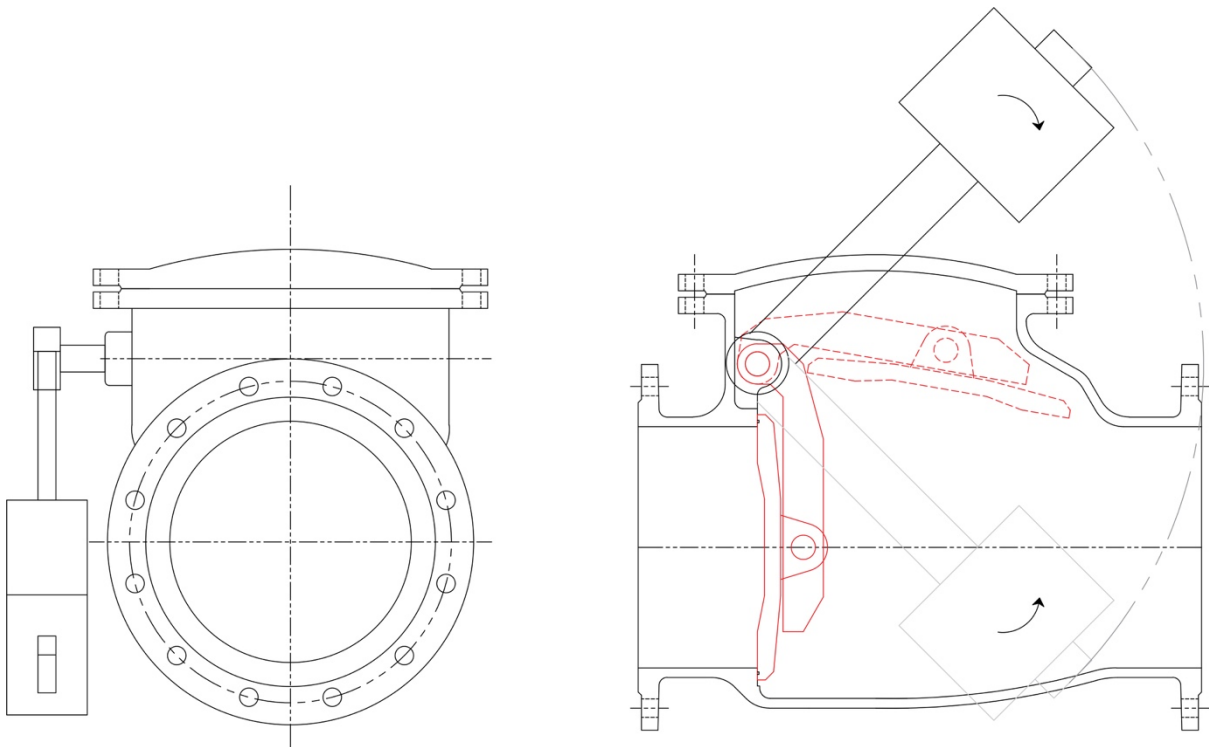

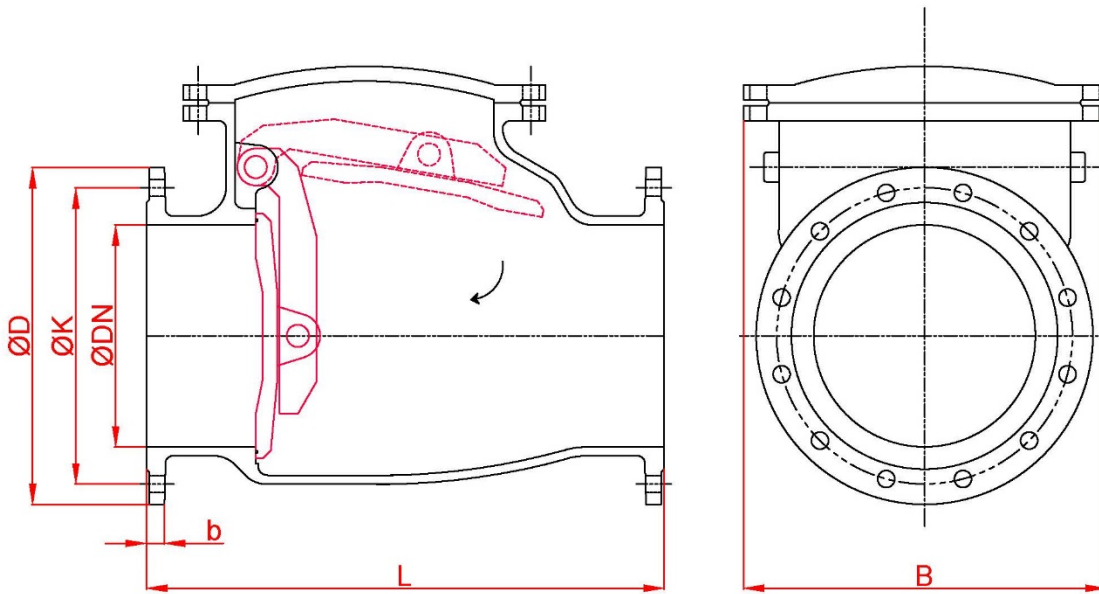

PN 10								PN 16						
DN	L	D	K	No. of Holes	d	b	Weight (kg)	L	D	K	No. of Holes	d	b	Weight (kg)
40	180	150	110	4	19	19	12	180	150	110	4	19	19	12
50	200	165	125	4	19	19	14	200	165	125	4	19	19	14
65	230	185	145	4	19	19	23	230	185	145	4	19	19	23
80	260	200	160	8	19	19	29	260	200	160	8	19	19	29
100	300	220	180	8	19	19	44	300	220	180	8	19	19	44
125	350	250	210	8	19	19	60	350	250	210	8	19	19	6*
150	400	285	240	8	23	19	76	400	285	240	8	23	19	76
200	500	340	295	8	23	20	130	500	340	295	12	23	20	130
250	600	400	350	12	23	22	185	600	400	355	12	28	22	185
300	700	455	400	12	23	24,5	270	700	455	410	12	28	24,5	270
350	800	505	460	16	23	24,5	355	800	520	470	16	28	26,5	355
400	900	565	515	16	28	24,5	480	900	580	525	16	31	28	480
500	1100	670	620	20	28	26,5	750	1100	715	650	20	34	31,5	750
600	1300	780	725	20	31	30	1025	1300	840	770	20	37	36	1025
700	1500	895	840	24	31	32,5	1565	1500	910	840	24	37	39,5	1565
800	1700	1015	950	24	34	35	2175	1700	1025	950	24	40	43	2175
900	1900	1115	1050	28	34	37,5	2980	1900	1125	1050	28	40	46,5	2980
1000	2100	1230	1160	28	37	40	3780	2100	1255	1170	28	43	50	3780

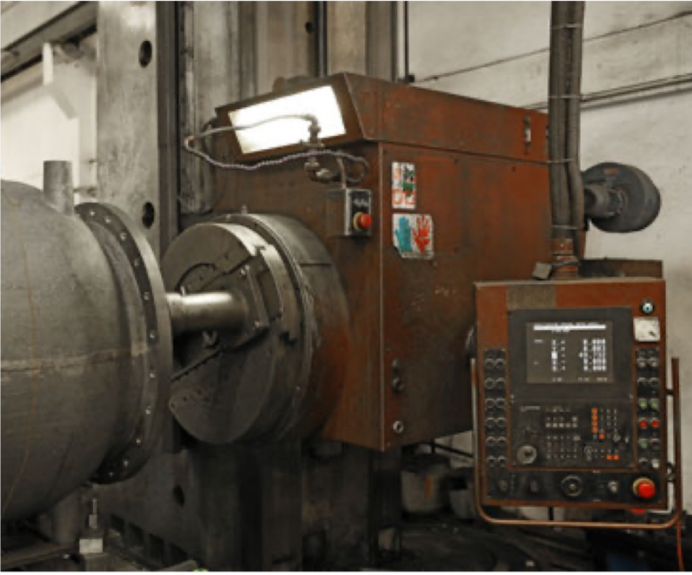



DESIGN

- TSE-EN 12334 certificated
- Double flanged
- Valve disk double offset
- Flanges DIN EN1092 - PN 10/16 norms
- Face to face EN558-1 Series 14, DIN3202 F4
- Body and disk sealing surface is corrosion – resistant stainless steel welded AISI 316
- Adjustable counterweight lever
- Maximum operating temperature 50 °C

MATERIAL

- Body and disk ductile iron GGG 40/50
- Valve shaft stainless steel AISI 420
- Shaft bearing is bronze
- Epoxy coating for drinking water

CONTROL

- Closing with counterweight
- Closing with hydraulic damper

OPTIONAL

- DN > 2000
- PN > 16
- Stainless steel disk and body
- Adjustable and replaceable EPDM sealing ring
- Disk designed with angle

CORROSION PROTECTION

- Electrostatic Powder Coating for Drinking Water
- Zinch – Rich Epoxy Primer
- Coal – Tar Epoxy
- Glass Flake Epoxy
- Enamel Epoxy for Ultraviolet
- Completely Stainless Steel Design
- Ebonite Coating for Seawater



TILTING CHECKVALVE WITH HYDROLIC DAMPER

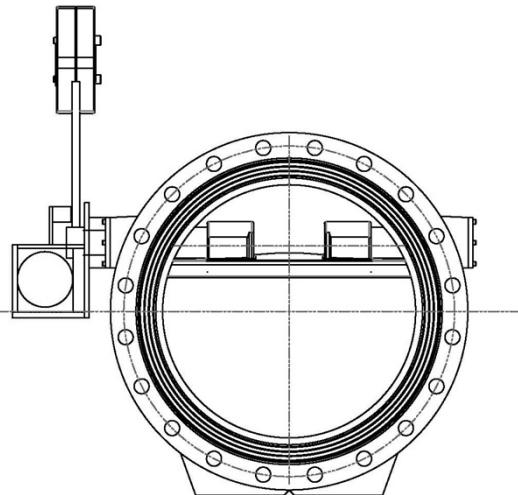
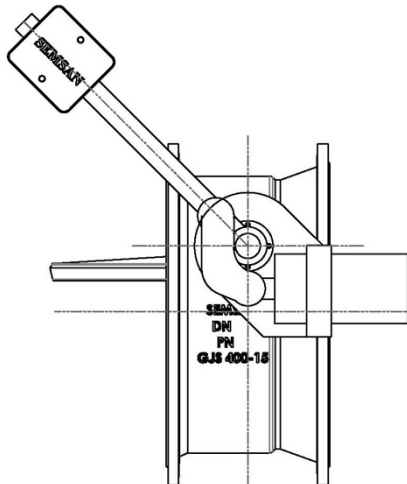
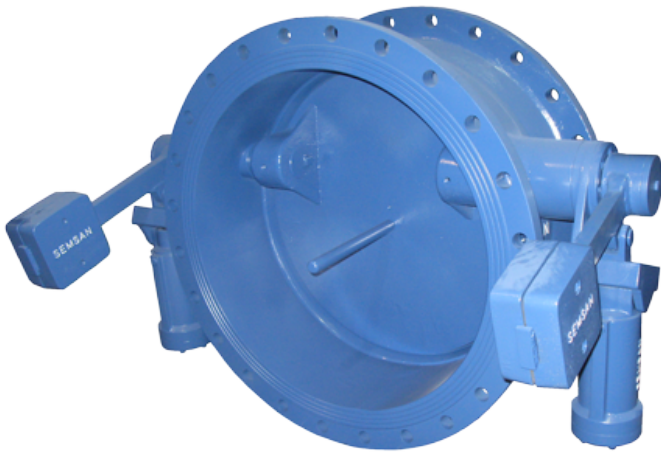
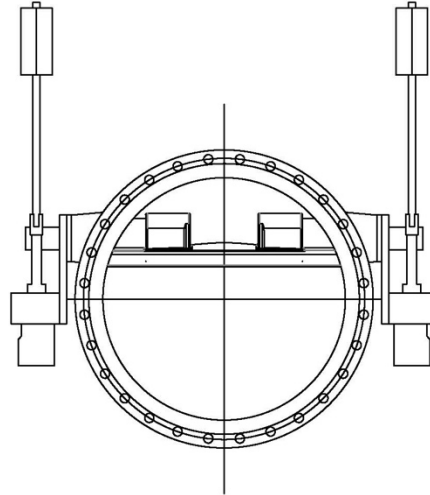
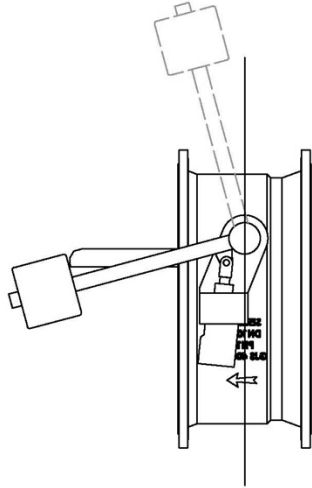

INTERNETIONAL STANDARTS FOR DESIGN		
MAIN TYPE	EN 16767	NON-SLAM NOZZLE TYPE CHECK VALVE
FACE TO FACE DIMENSONS	EN 558 - 1	SERIES 14
FLANGE DIMENSIONS	EN 1092	Flange norm can be revise up to customer
FINAL ACCEPTANCE TEST	EN12266 1 - 2	Rate A (Zero Leakage)
DESIGN TEST	1074 / EN 1267	
BODY AND DISC MATERIALS	EN1563 / AISI / EN 10202 / EN 10213	
SHAFT MATERIAL	EN 10088 / AISI	
BEARING MATERIALS	EN 1982	
COATING	EN ISO 12944 / EN ISO 2409 / EN ISO 4624 (min 250 mikron - electropowder epoxy up to DN1400; DN1500 and bigger wet epoxy)	
COATING FOR SEAWATER	min 3 mm ebonite coating / Glass Flake Epoxy Coating	
CERTIFICATION	10204 3.1 (non witnessed) 10204 3.2 (witnessed) Third Party Tests Raw Material Certificates	

TESTS	
LEAKAGE TEST	1.1 x PN
LOW PRESSURE LEAKAGE	0,2 ATM (zero leakage)
BODY TEST	1,5 X PN
COATING THICKNESS TEST	min 250 mikron
OPERATIONAL TEST	CLOSING TEST
MATERIAL TESTS	MECHANICAL, CHEMICAL, MICROSTRUCTURE

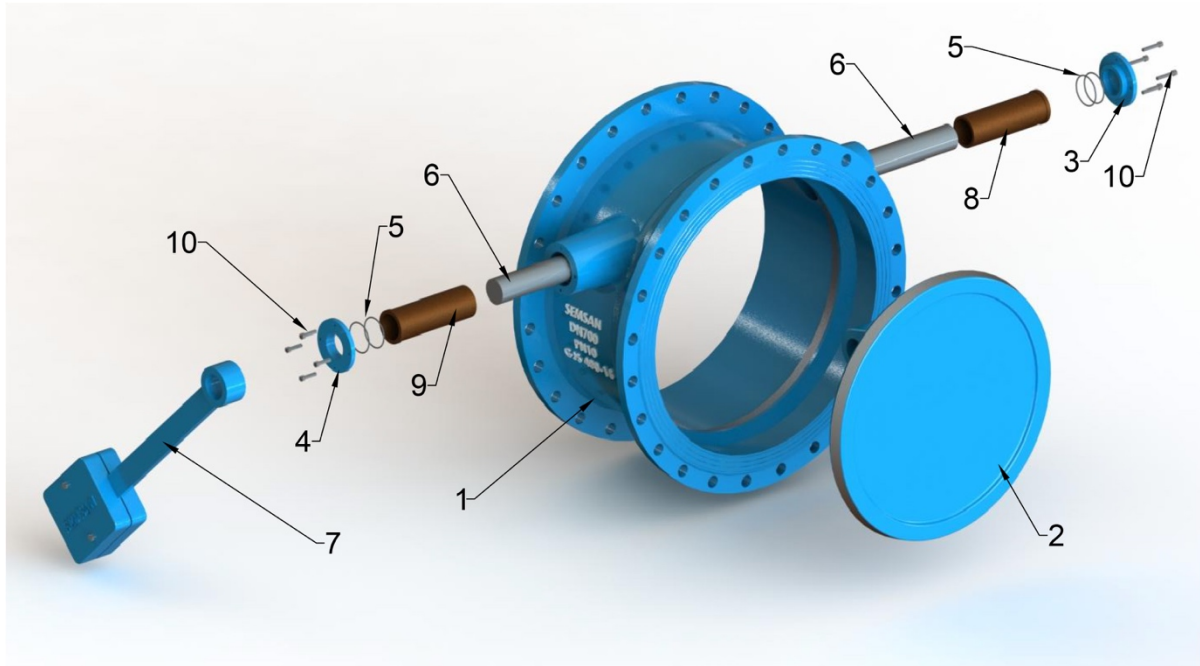

NO	PART	STANDART MATERIAL	OPTIONAL MATERIALS
1	VALVE BODY	DUCTILE IRON GJS400.15 / GJS400.18 / GJS500.7 / GJS500.14	STAINLESS STEEL AISI 304 / AISI 316 / AISI 329 Duplex (S32900)
2	VALVE DISC	DUCTILE IRON GJS400.15 / GJS400.18 / GJS500.7 / GJS500.14	STAINLESS STEEL AISI 304 / AISI 316 / AISI 329 Duplex (S32900)
3, 4	BLIND AND SHAFT LID	DUCTILE IRON GJS400.15 / GJS400.18 / GJS500.7 / GJS500.14	DUCTILE IRON GJS400.15 / GJS400.18 / GJS500.7 / GJS500.14
5	O-RING	EPDM	NBR
6	SHAFT	1.4021 (AISI420) / 1.4057 (AISI431)	1.4462 (Duplex SS)
7	COUNTERWEIGHT LEVEL	S235JR	
8-9	BEARING BUSH	GCuSn10	ZincFree Bronze
10	BOLTS	A2	A4
11	BODY AND DISC SEAT	AISI 309L Si	AISI 316L Si

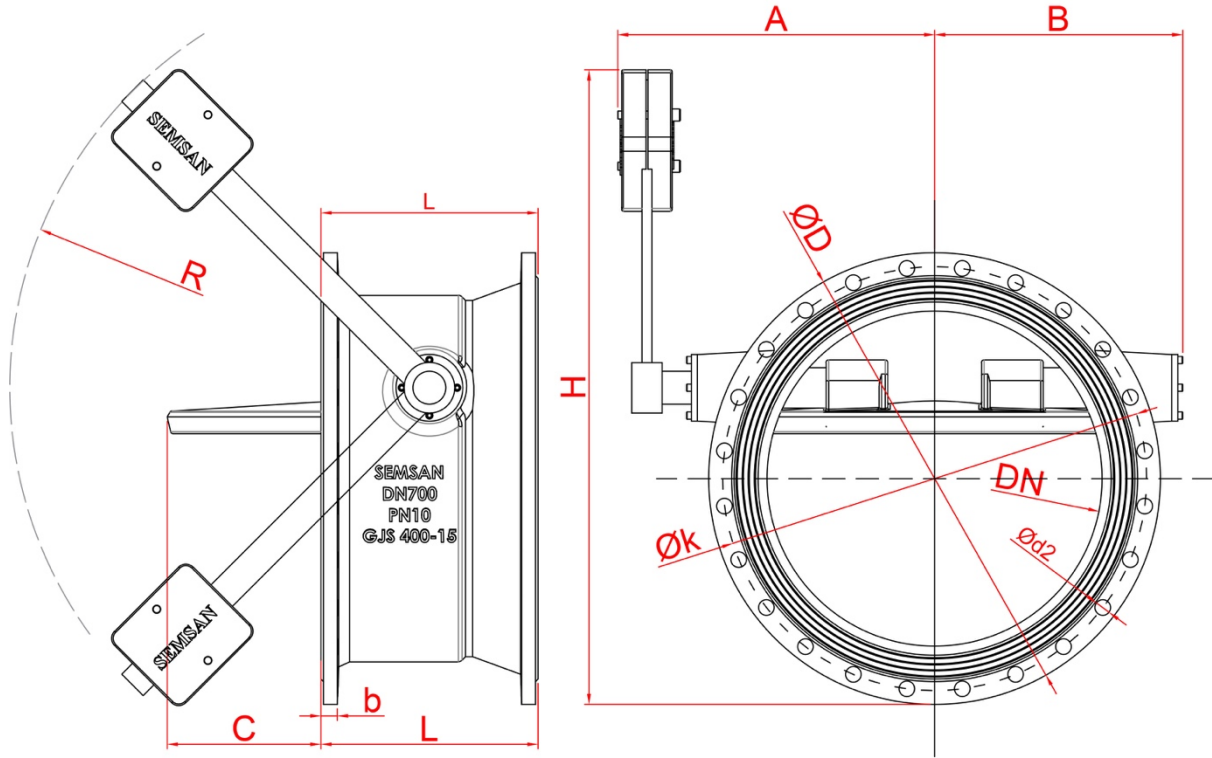

(DN)	NOMINAL						PN10	PN16	PN25
	A	B	C	L	H	R	WEIGHT	WEIGHT	WEIGHT
200	305	170	35	230	400	250	58	58	88
250	360	200	63	250	437	250	85	85	95
300	385	233	90	270	525	300	107	116	146
350	410	275	118	290	562	300	134	136	189
400	402	283	140	310	640	300	155	194	283
500	481	350	195	350	825	400	250	309	468
600	547	398	255	390	990	500	359	537	607
700	672	490	305	430	1165	600	522	697	948
800	770	545	365	470	1300	660	672	791	1208
900	813	586	420	510	1375	660	934	999	1903
1000	882	650	465	550	1560	760	1220	1386	2142
1200	1063	750	585	630	1840	900	1793	2174	2940
1400	1158	890	705	710	2075	1000	2621	3004	4080
1600	1275	1000	825	790	2330	1100	4402	4584	5775
1800	1375	1100	945	870	2660	1300	5321	5586	9180
2000	1525	1200	1065	950	2910	1400	7324	7748	11730



NON-SLAM NOZZLE CHECK VALVE

DN 100/1800
PN 10 - 64

DESIGN

- TS EN 16767 certificated
- Double flange
- Flanges DIN EN1092
- PN 10/16/25/40/64
- Face to face EN 558-1 series 14 (DIN3202, F4)
- One piece rigid design
- Body sealing surface; corrosion-resistant stainless steel welded AISI 316 and microfinished
- Axial closing design by spring
- Axial movement by disk
- Replaceable inside parts
- EPDM sealing ring
- Internal fasteners of valve are stainless steel

MATERIAL

- Body ductile iron GGG40/50
- Disk ductile iron GGG40/50
- EPDM sealing ring
- Checkvalve shaft is; AISI 420 (X20Cr13)
- Shaft bearing is bronze

OPTIONAL

- DN > 1600
- Stainless steel body and disk

CORROSION PROTECTION

- Electrostatic Powder Coating for Drinking Water
- Zinch – Rich Epoxy Primer
- Coal – Tar Epoxy
- Glass Flake Epoxy
- Enamel Epoxy for Ultraviolet
- Completely Stainless Steel Design
- Ebonite Coating for Seawater



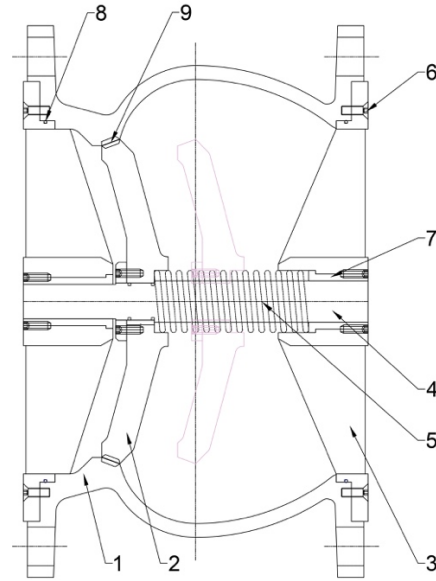
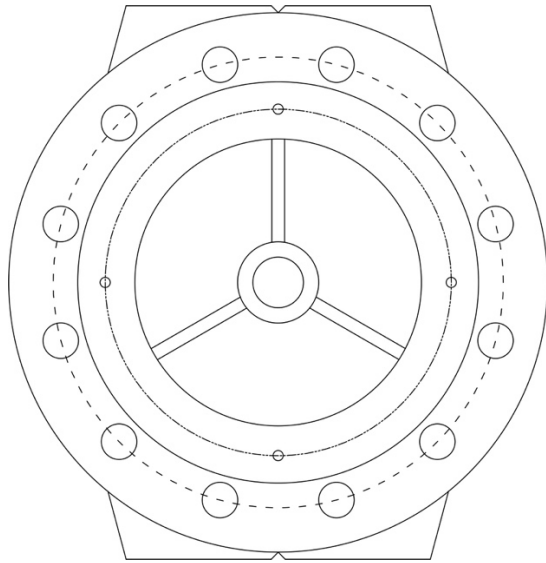

NO	PART	STANDART MATERIAL	OPTIONAL MATERIALS
1	VALVE BODY	DUCTILE IRON GJS400.15 / GJS400.18 / GJS500.7 / GJS500.14	STAINLESS STEEL AISI 304 / AISI 316 / AISI 329 Duplex (S32900)
2	VALVE DISC	DUCTILE IRON GJS400.15 / GJS400.18 / GJS500.7 / GJS500.14	STAINLESS STEEL AISI 304 / AISI 316 / AISI 329 Duplex (S32900)
3	FLOW DIFFUSOR	DUCTILE IRON GJS400.15 / GJS400.18 / GJS500.7 / GJS500.14	STAINLESS STEEL AISI 304 / AISI 316 / AISI 329 Duplex (S32900)
4	SHAFT	1.4021 (AISI420) / 1.4057 (AISI431)	1.4462 (Duplex SS)
5	SPRING	EN10270-3 STAINLESS STEEL	AISI316
6	BOLTS	A2	A4
7	BEARING BUSH	GCuSn10	ZincFree Bronze
8	O-RING	EPDM	NBR
9	BODY AND DISC SEAT	AISI 309L Si	AISI 316L Si

TESTS	
LEAKAGE TEST	1.1 x PN
LOW PRESSURE LEAKAGE	0,2 ATM (zero leakage)
BODY TEST	1,5 X PN
COATING THICKNESS TEST	min 250 mikron
OPERATIONAL TEST	CLOSING TEST
MATERIAL TESTS	MECHANICAL, CHEMICAL, MICROSTRUCTURE

INTERNETIONAL STANDARTS FOR DESIGN		
MAIN TYPE	EN 16767	NON-SLAM NOZZLE TYPE CHECK VALVE
FACE TO FACE DIMENSONS	EN 558 - 1	SERIES 14
FLANGE DIMENSIONS	EN 1092	Flange norm can be revise up to customer
FINAL ACCEPTANCE TEST	EN12266 1 - 2	Rate A (Zero Leakage)
DESIGN TEST	1074 / EN 1267	
BODY AND DISC MATERIALS	EN1563 / AISI / EN 10202 / EN 10213	
SHAFT MATERIAL	EN 10088 / AISI	
BEARING MATERIALS	EN 1982	
COATING	EN ISO 12944 / EN ISO 2409 / EN ISO 4624 (min 250 mikron - electropowder epoxy up to DN1400; DN1500 and bigger wet epoxy)	
COATING FOR SEAWATER	min 3 mm ebonite coating / Glass Flake Epoxy Coating	
CERTIFICATION	10204 3.1 (non witnessed) 10204 3.2 (witnessed) Third Party Tests Raw Material Certificates	



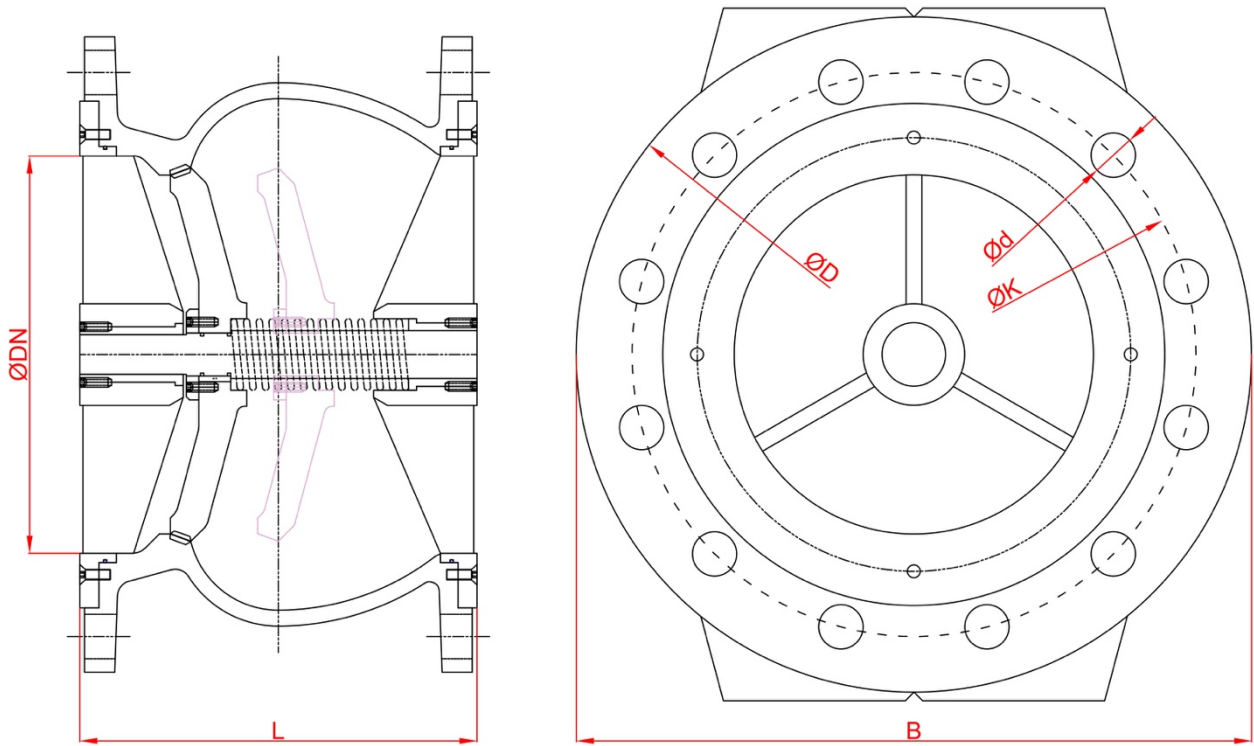

DN	SERIES 15	PN10						PN16					
		B / D	K	No of Holes	d	b	Weight (kg)	B / D	K	No of Holes	d	b	Weight (kg)
100	190	220	180	8	19	19	25	220	180	8	19	19	25
125	200	250	210	8	19	19	32	250	210	8	19	19	35
150	210	285	240	8	23	19	40	285	240	8	23	19	40
200	230	340	295	8	23	20	60	340	295	12	23	20	60
250	250	400	350	12	23	22	80	400	355	12	28	22	80
300	270	455	400	12	23	24,5	110	455	410	12	28	24,5	110
350	290	505	460	16	23	24,5	130	520	470	16	28	26,5	130
400	310	565	515	16	28	24,5	160	580	525	16	31	28	160
450	330	615	565	20	28	25,5	237	640	585	20	31	30	237
500	350	670	620	20	28	26,5	300	715	650	20	34	31,5	300
600	390	780	725	20	31	30	460	840	770	20	37	36	460
700	430	895	840	24	31	32,5	670	910	840	24	37	39,5	670
800	470	1015	950	24	34	35	775	1025	950	24	40	43	775
900	510	1115	1050	28	34	37,5	970	1125	1050	28	40	46,5	970
1000	550	1230	1160	28	37	40	1078	1255	1170	28	43	50	1078
1100	590	1340	1270	32	37	43	1328	1355	1270	32	43	53,5	1328
1200	630	1455	1380	32	41	45	1848	1485	1390	32	49	57	1848
1300	670	1570	1490	32	44	45	2080	1585	1490	32	49	58	2080
1400	710	1675	1590	36	44	46	2270	1685	1590	36	49	60	2270
1500	750	1785	1700	36	44	47,5	3351	1820	1710	36	57	62,5	3351
1600	790	1915	1820	40	50	49	4385	1930	1820	40	57	65	4385
1800	870	2115	2020	44	50	52	6350	2130	2020	44	57	70	6350

DN	SERIES 15	PN25							PN40					
		L	B / D	K	No of Holes	d	b	Weight (kg)	B / D	K	No of Holes	d	b	Weight (kg)
100	190	190	220	180	8	19	19	30	235	190	8	22	24	30
125	200	200	270	220	8	28	19	35	270	220	8	26	26	45
150	210	210	300	250	8	28	20	55	300	250	8	26	28	70
200	230	230	360	310	12	28	22	75	375	320	12	30	34	100
250	250	250	425	370	12	31	24,5	100	450	385	12	33	38	150
300	270	270	485	430	16	31	27,5	130	515	450	16	33	42	170
350	290	290	555	490	16	34	30	155	580	510	16	36	46	185
400	310	310	620	550	16	37	32	200	660	585	16	39	50	300
450	330	330	670	600	20	37	34,5	280	685	610	20	39	50	389
500	350	350	730	660	20	37	36,5	380	755	670	20	42	52	480
600	390	390	845	770	20	40	42	490	890	795	20	48	60	650
700	430	430	960	875	24	43	46,5	780	995	900	20	48	64	945
800	470	470	1085	990	24	49	51	900	1140	1030	24	56	72	1350
900	510	510	1185	1090	28	49	55,5	1250	1250	1140	28	56	76	1830
1000	550	550	1320	1210	28	56	60	1685	1360	1250	28	56	80	2475
1100	590	590	1420	1310	32	56	64	1950	1470	1380	28	56	84	2865
1200	630	630	1530	1420	32	56	69	2400	1575	1460	32	62	88	3600



Semsan
PUMPS AND VALVES COMPANY



www.semsan.com.tr

SUBMERSIBLE SEWAGE PUMP

DN 50/800 | 1,3 - 630 KW



MATERIAL

- Motor body ductile iron GGG 40/50
- Cooling jacket ST37-2 / AISI 304
- Motor shaft is AISI 420 X20Cr13
- Fasteners AISI316
- Impeller is ductile iron GGG/40/50

FOR WET MOUNTING

- Pedestal, ductile iron GGG 40-50 / stainless steel
- Fasteners are galvanized steel
- Pipe coupling socket is ductile iron GGG 40/50

FOR DRY MOUNTING

- Pump chassis ST37-2

**Please contact for your different material requests.

SPECIFICATIONS

- Discharge Outlets DN50-800
- Motor power is 1,3-630 kw
- Operating voltage is 380 V 50 Hz (3 phase)
- Insulation class: H
- Protection class: IP68
- Type of starting: star delta, directly, soft starter
- Type of cable: H07RNF
- Standart cable length is 10 meters
- Mechanical seal SiC-SiC / W-C

DESIGN

- TS EN 12599 certificated
- 380 V 50 Hz 3phase squirrel cage motor
- Motor insulation class H
- 1,3- 7,5 kw cooling vane (cooling jacket is optional)
- 11-630 kw closed circuit cooling system
- DI sealing sensor in the oil reservoir between the electric motor and the pump
- Maintenance free bearings
- There is a thermister temperature sensor for protect over heating of motor
- Stainless steel shaft
- Optionally completely in stainless steel manufacturing
- Custom manufacturing according to the type of fluid
- Dry, wet, horizontal and vertical mounting ability
- Epoxy coating

TYPE OF IMPELLER

- SO : One Vane Open
- DO : Two Vane Open
- TO : Three Vane Open
- SC : One Channel Closed
- DC : Two Channel Closed
- TC : Three Channel Closed
- VX : Vortex

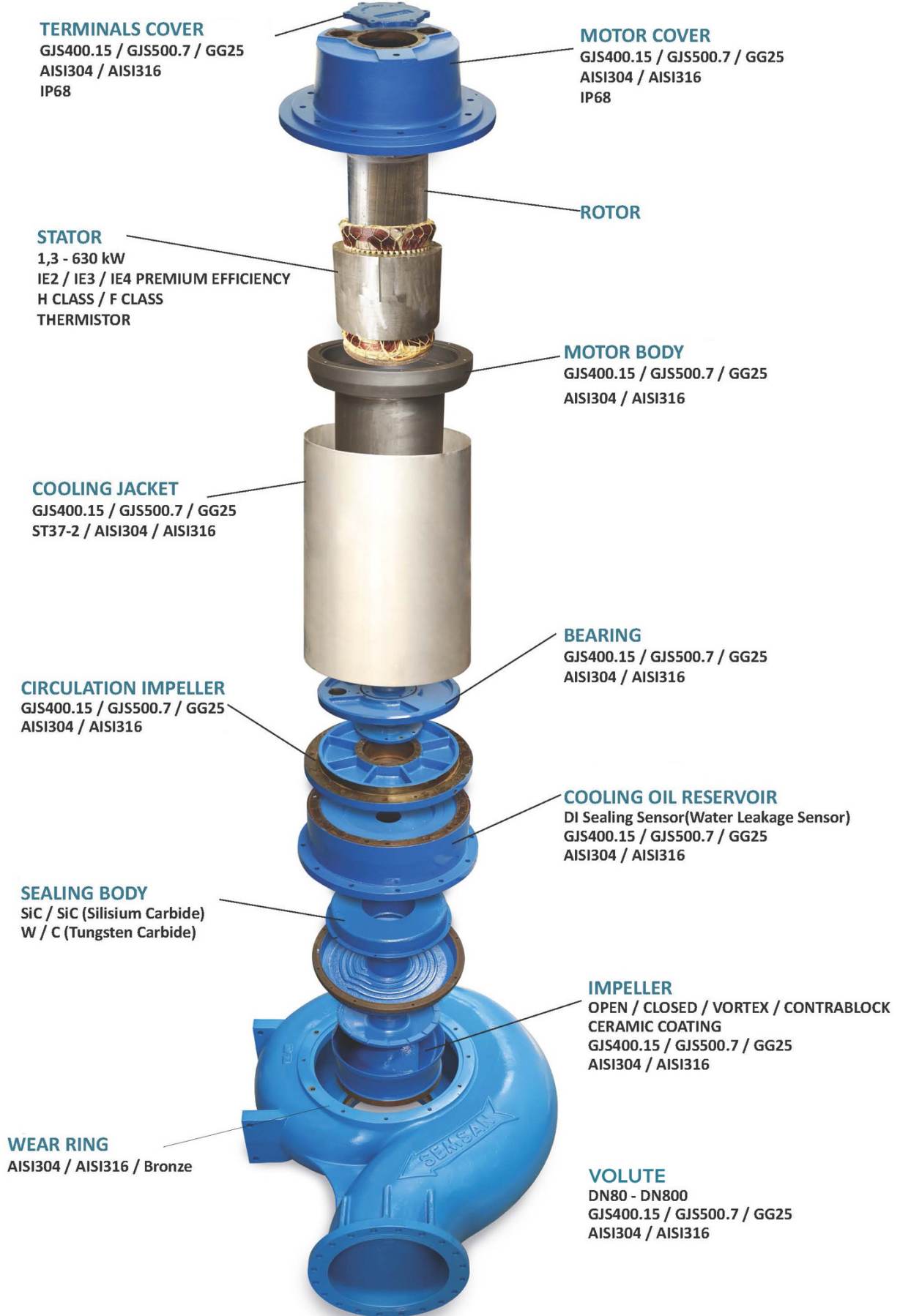

SUBMERSIBLE SEWAGE PUMP CLOSED CIRCUIT COOLING SYSTEM

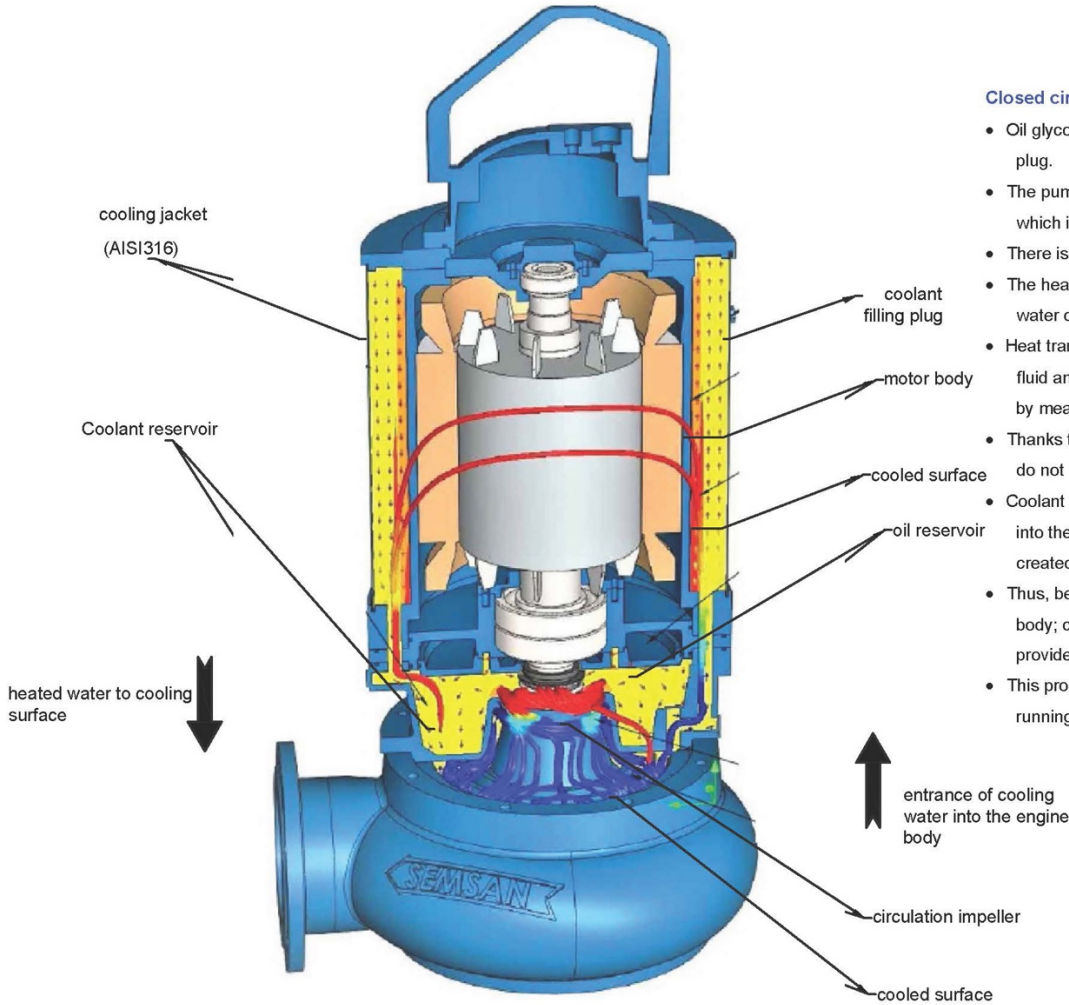

Closed circuit cooling system working principle

- Oil glycol mixture coolant is filled from the cooling plug.
- The pump transfers the heat of the stator body, which is heated during operation, to the water.
- There is a circulation impeller on the main shaft.
- The heated water is transferred into the cooling water chamber through this impeller.
- Heat transfer is provided between the circulating fluid and the fluid pressed by the pump in the snail by means of the fin plate in the coolant reservoir.
- Thanks to this separator plate, two different liquids do not mix.
- Coolant cooling down on the fins; It is sent back into the engine body with the pressure difference created by the circulation impeller.
- Thus, between the cooling jacket and the engine body; continuous chilled liquid circulation is provided.
- This process continues as long as the pump is running.

SUBMERSIBLE SEWAGE PUMP PERFORMANCE EFFICIENCY TEST REPORT

TEKİF NO		HİDROLİK VERİLER			ELEKTRİK VERİLER		
Pompa Modeli	ASP 100 260 M185 4	Debi (Q)	77,7 lt/sn	Motor Gücü (N)	18,5 kW		
İmal Yılı / Seri No	2016 / KUTLAR 002	Yükseklik (Hm)	15 mSS	Devir (n)	1475 d/dak		
Test Tarihi / Saati	22.02.2016 / 16.57	Randiman (np)	66 %	Motor Randımanı	91,3 %		
Test No	1	Basma Açığı (DN)	150 mm	TEST STANDI VERİLERİ			
Özel Notlar: Pedestallı,		Fan Tipi	2 kanat açık	Boru Çapı (DN)	0,13 mt		
		Fan Çapı	270	Su Seviyesi (m3)	1,4 mt		

Debi (Q)	lt/sn	0	13	24	44	54	64	73	97	114
Basınç Transmitteri	mt.	21,9	20,8	19,2	16,6	15,2	14,0	12,5	7,4	3,6
Toplam Güç (N)	kW	13,6	14,1	14,5	16,2	16,9	17,8	18,3	18,2	16,9
Hız (V)	m/sn	0,00	0,97	1,80	3,34	4,07	4,81	5,51	7,33	8,62
Hız Yükseklik Farkı	mt.	0	0,0482	0,166	0,57	0,845	1,181	1,545	2,736	3,784
Toplam Manometrik Yükseklik (mSS)	Hm	23	22	21	19	17	17	15	12	9
Mil Gücü (Np)	kW	12,4	12,8	13,3	14,8	15,4	16,3	16,7	16,6	15,4
Pompa Randımanı (np)	%	0	22	37	55	60	64	66	66	63,51

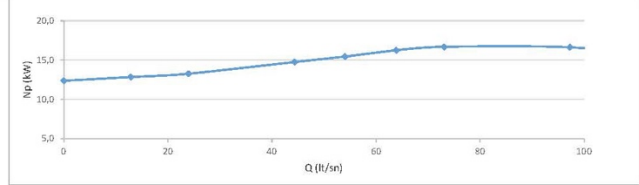
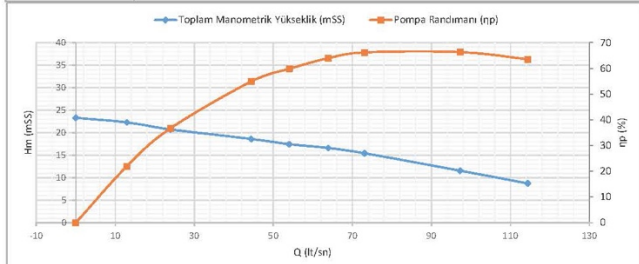

SUBMERSIBLE SEWAGE PUMP PERFORMANCE CURVE

Customer	Order No
	Date 23.08.2016

PUMP SPECIFICATIONS			MOTOR SPECIFICATIONS		
Model	ASP100-260 M3150 / 8	Suction / Discharge	DN 500	Motor Power (N)	315 kW
Flow Rate (Q)	4000 m ³ /h	Impeller Type	3 Ch Closed	Speed (n)	740 d/dak
Flow Rate (Q)	1111,1 lt/sn	Impeller Dia	660 mm	Operation Voltage	380 V
Head (Hm)	19 mSS	Solid Size	120 mm	Frequency	50 Hz
Operation Temp.	40 °C	Efficiency (np)	82 %	Insulation Class	H/Class
Protection Class	IP68	Power (N)	252,4 Kw	Cable Length	10 mt

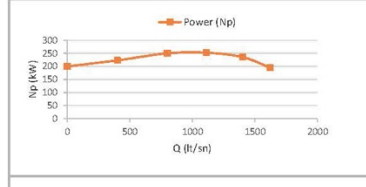
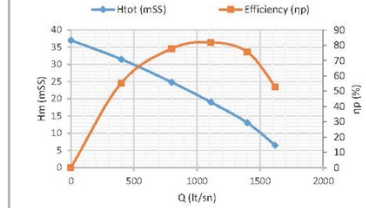

MATERIAL

Body: GJS 400/15 (GGG 40) - Ductile Iron
 Pump Snail: GJS 400/15 (GGG 40) - Ductile Iron
 Impeller: GJS 400/15 (GGG 40) - Ductile Iron
 Shaft: AISI 420 (X20Cr13) Stainless Steel
 Sealing: SIC / SIC

DESIGN

- * Thermistor Temperature Sensor for Protect Over Heating of Motor.
- * DI Sealing Sensor in the Oil Reservoir Between * The Electric Motor and the Pump
- * Closed Circuit Cooling System
- * Cooling Jacket for Dry Mounting
- * Double Mechanical Seal for Pump Sealing
- * Maintenance Free Bearings

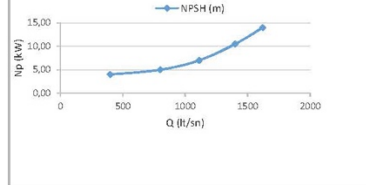

EN ISO 9906
PUMP TEST
STAND



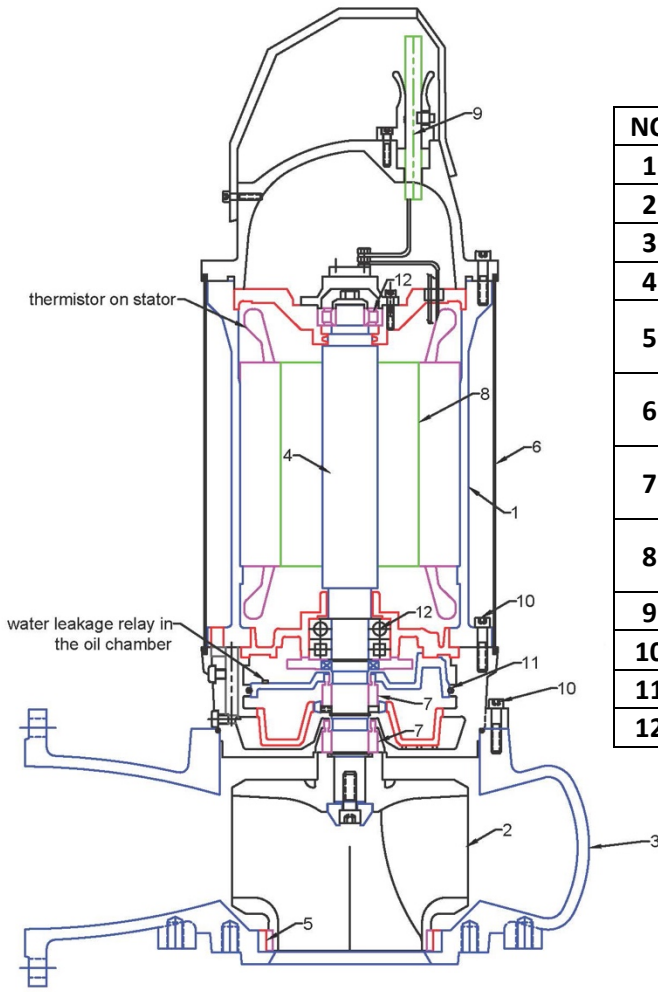

NO	PART NAME	MATERIAL LIST
1	Body	GJS 400.15 Ductile iron
2	Impeller	GJS 400.15 Ductile iron
3	Snail	GJS 400.15 Ductile iron
4	Pump shaft	AISI 420 (X20Cr13)
5	Wear Ring (impeller and snail)	AISI 316/304 Stainless steel
6	Cooling Jacket	AISI 316/304 Stainless steel OR steell
7	Mechanical Seal	Double Mechanical Seal in accordance with DIN 24960 (SiC/SiC or WC)
8	Motor	IE2 380V 50 Hz 3 phase H Class
9	Cable	H07RNF
10	Bults and nuts	A2 stainless steel
11	Seals	EPDM
12	Bearings	Ground, metal bodied bearing

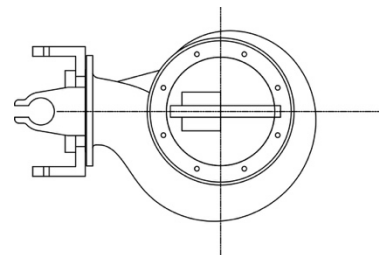
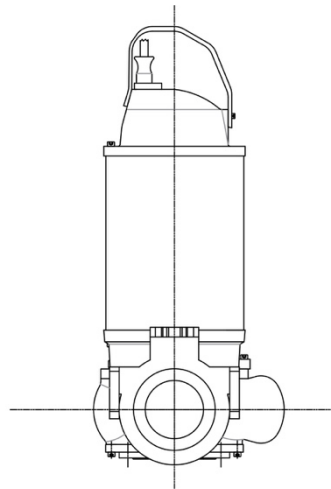
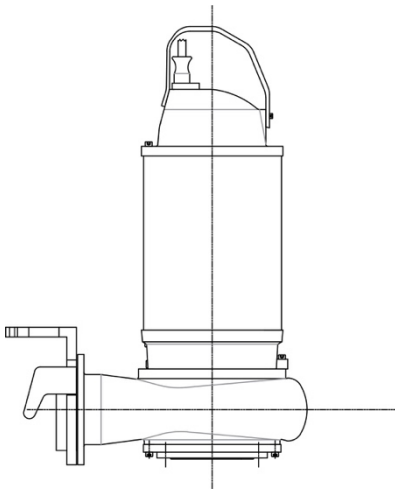

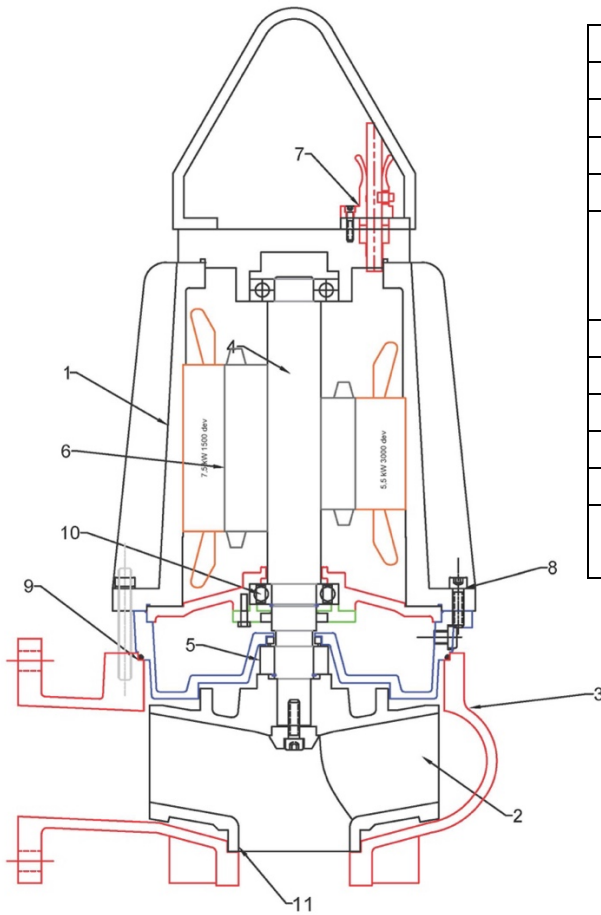

NO	PART NAME	MATERIAL LIST
1	Body	GJS 400.15 Ductile iron
2	Impeller	GJS 400.15 Ductile iron
3	Snail	GJS 400.15 Ductile iron
4	Pump shaft	AISI 420 (X20Cr13)
5	Mechanical Seal	Double Mechanical Seal in accordance with DIN 24960 (SiC/SiC or WC)
6	Motor	IE2/IE3 380V 50 Hz 3 phase H Class
7	Cable	H07RNF
8	Bolt and Nuts	A2 Stainless Steel
9	Seals	EPDM
10	Berings	Ground, metal bodied bearing
11	Wear Ring (impeller and snail)	AISI 316/304 Stainless Steel

TK Impeller Type

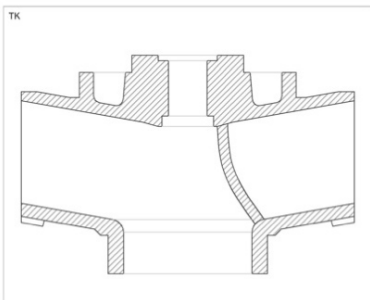

TA Impeller Type

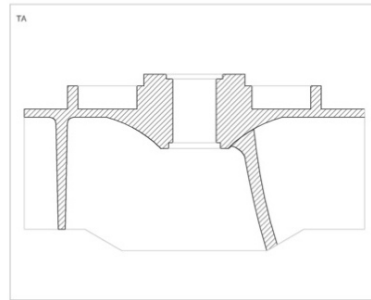

V Impeller Type

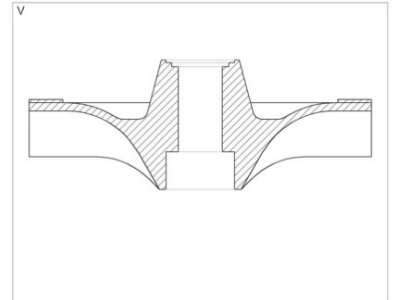

CK Impeller Type

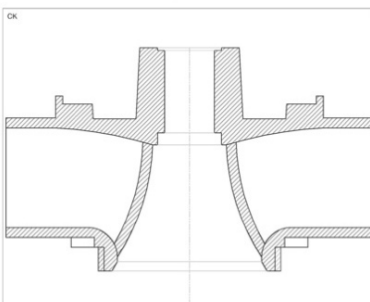

CA Impeller Type

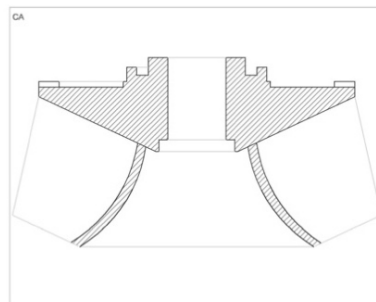

UK Impeller Type

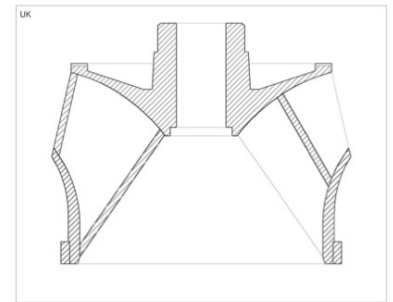

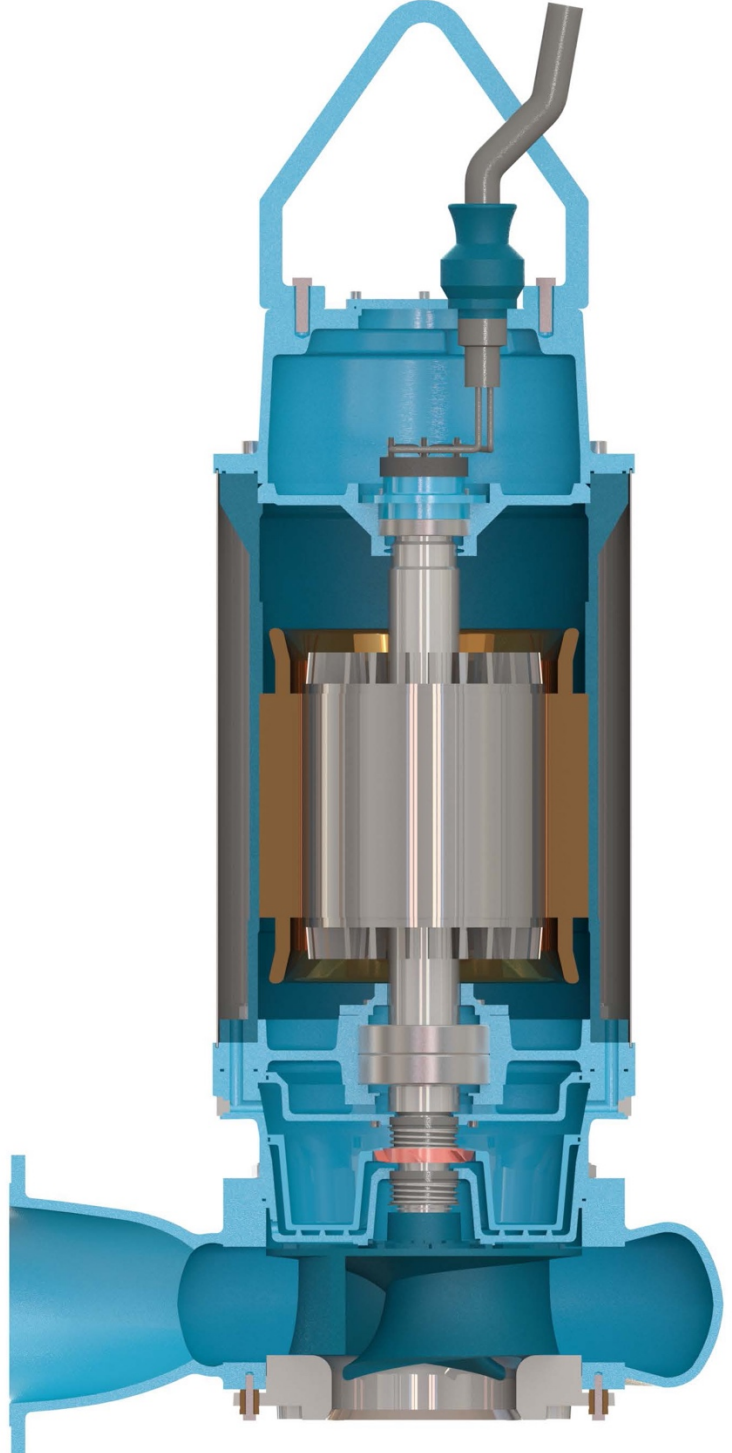

PUMP CODE	IMPELLER TYPE		SOLID SIZE	OUTLET	INLET	NO OF POLES	N (kW)	Qnom (lt/sn)	Hmax (mWC)						
ASP 080 SO T1	SO	T1	65	080	080	2 / 4 / 6	1,5 - 11	5 - 35	70						
ASP 080 SC T2	SC	T2	65												
ASP 080 VX T1	VX	T1	75												
ASP 080 VX T2	VX	T2	75												
ASP 100 SO T1	SO	T1	65	100	100	2 / 4	3 - 75	5 - 65	70						
ASP 100 SO T2	SO	T2	65												
ASP 100 SO T3	SO	T3	65												
ASP 100 SC T1	SC	T1	75												
ASP 100 SC T2	SC	T2	75												
ASP 100 VX T1	VX	T1	100												
ASP 100 VX T2	VX	T2	100												
ASP 100 DO T1	DO	T1	77 x 52												
ASP 100 DO T2	DO	T2	75												
ASP 100 DC T1	DC	T1	75												
ASP 100 DC T2	DC	T2	75												
ASP 150 SO T1	SO	T1	80 x 100							150	150	4 / 6	11 - 75	20 - 150	70
ASP 150 SO T2	SO	T2	80 x 100												
ASP 150 SC T1	SC	T1	80 x 100												
ASP 150 SC T2	SC	T2	80 x 100												
ASP 150 DO T1	DO	T1	100												
ASP 150 DO T2	DO	T2	100												
ASP 150 DC T1	DC	T1	80 x 100												
ASP 150 DC T2	DC	T2	80 x 100												
ASP 150/100 SO T3	SO	T3	80 x 100	/100											
ASP 150/100 DO T3	DO	T3	80 x 100	/100											
ASP 200 SO T1	SO	T1	100	200	200	4 / 6	18,5 - 132	35 - 215	70						
ASP 200 SC T1	SC	T1	100												
ASP 200 DO T1	DO	T1	100												
ASP 200 DO T2	DO	T2	100												
ASP 200 DC T1	DC	T1	100												
ASP 200 DC T2	DC	T2	100												
ASP 200/150 SO T3	SO	T3	100							/150					
ASP 200/150 DO T3	DO	T3	100							/150					
ASP 250 DO T1	DO	T1	90 x 110	250	250	4 - 6	11 - 250	100 - 360	70						
ASP 250 DO T2	DO	T2	90 x 110												
ASP 250 DC T1	DC	T1	90 x 110												
ASP 250 DC T2	DC	T2	90 x 110												
ASP 300 DO T1	DO	T1	90 x 125	300	300	4 / 6 / 8	30 - 315	150 - 550	50						
ASP 300 DO T2	DO	T2	90 x 125												
ASP 300 DC T1	DC	T1	90 x 125												
ASP 300 DC T2	DC	T2	90 x 125												
ASP 300 TOT1	TO	T1	90 x 125												
ASP 300 TCT1	TC	T1	90 x 125												
ASP 400 DO T1	DO	T1	100 x 130	400	400	6 / 8	30 - 315	200 - 750	35						
ASP 400 DC T1	DC	T1	100 x 130												
ASP 400 TOT1	TO	T1	100 x 130												
ASP 400 TCT1	TC	T1	100 x 130												
ASP 500 TOT1	TO	T1	130 x 150	500	500	6 / 8	45 - 450	400 - 1200	35						
ASP 500 TCT1	TC	T1	130 x 150												
ASP 600 TOT1	TO	T1	175	600	600	6 / 8 / 10	110 - 500	800 - 1600	25						
ASP 600 TCT1	TC	T1	175												
ASP 800 TOT1	TO	T1	255	800	800	8 / 10	110 - 630	1200 - 2500	20						
ASP 800 TCT1	TC	T1	255												

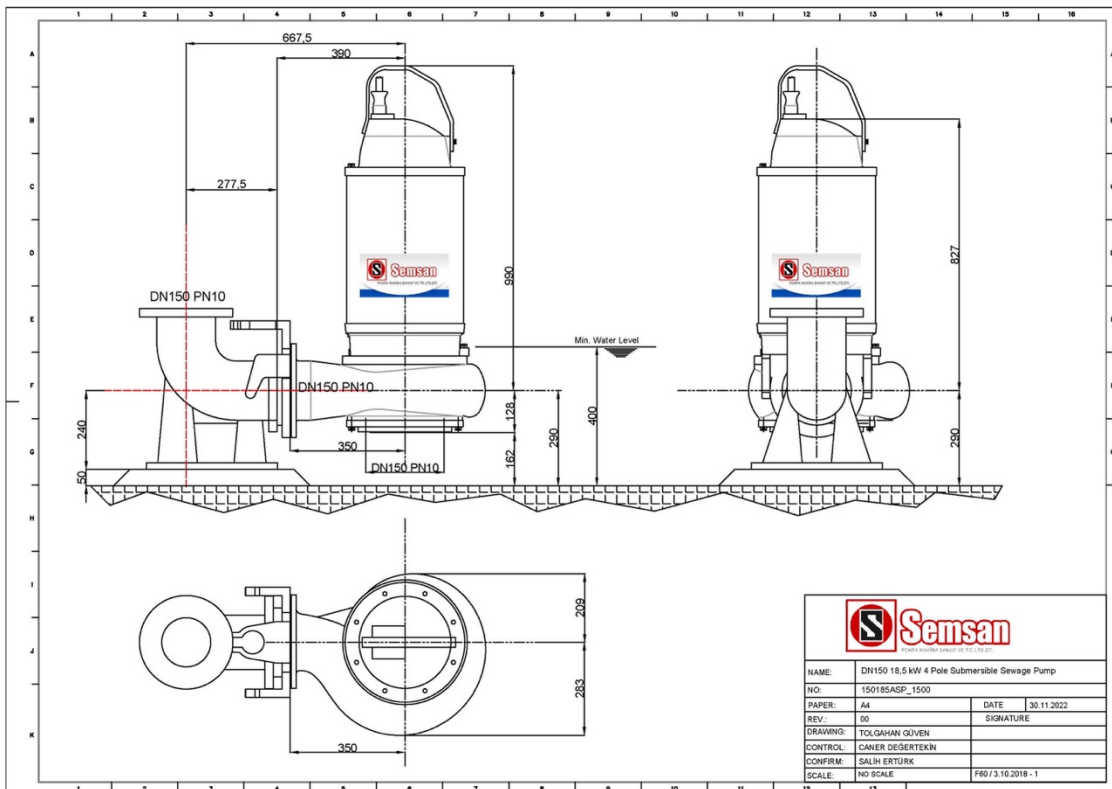
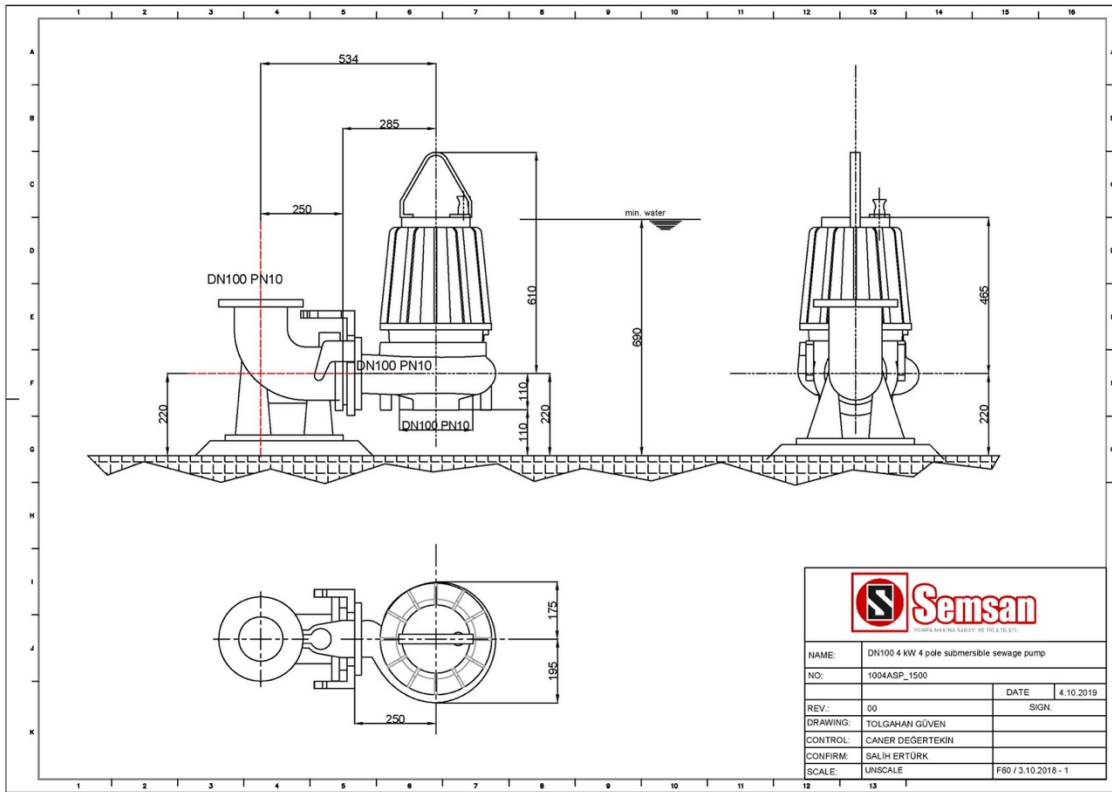

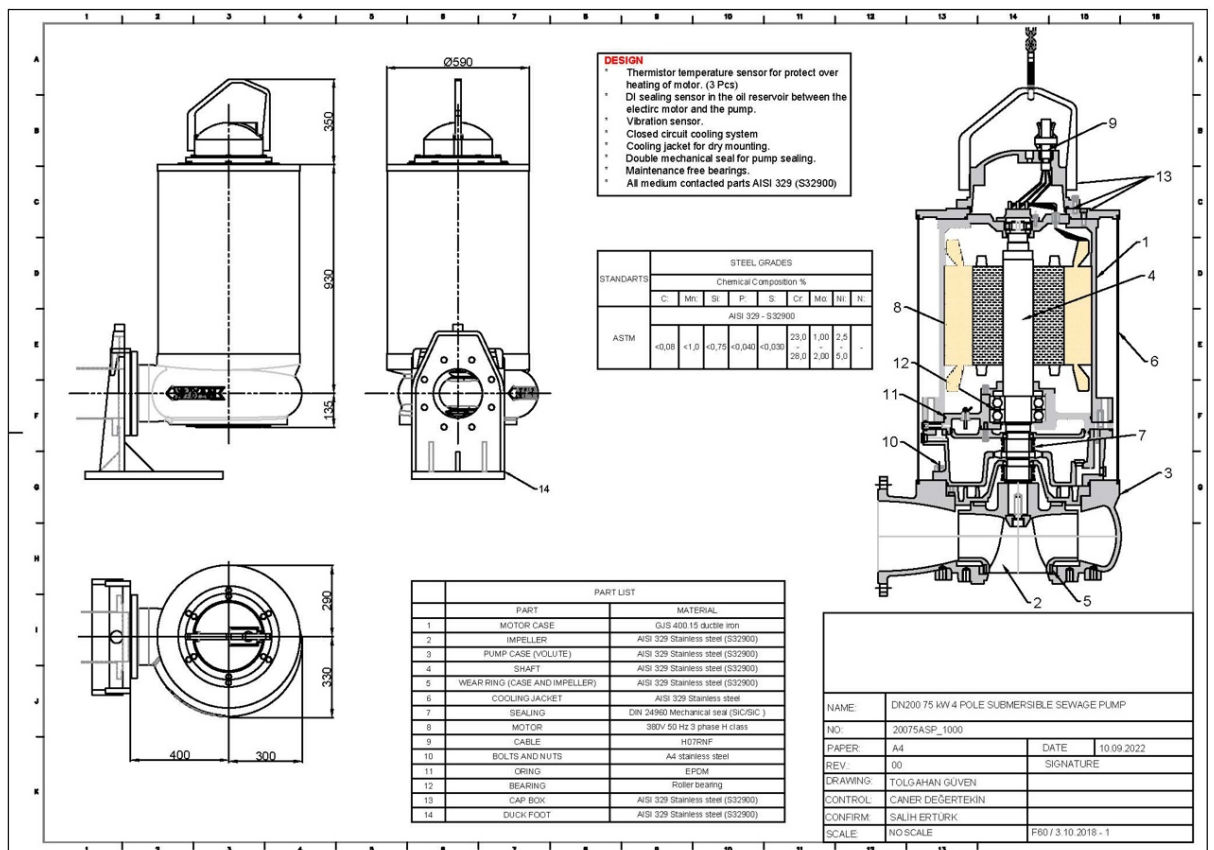
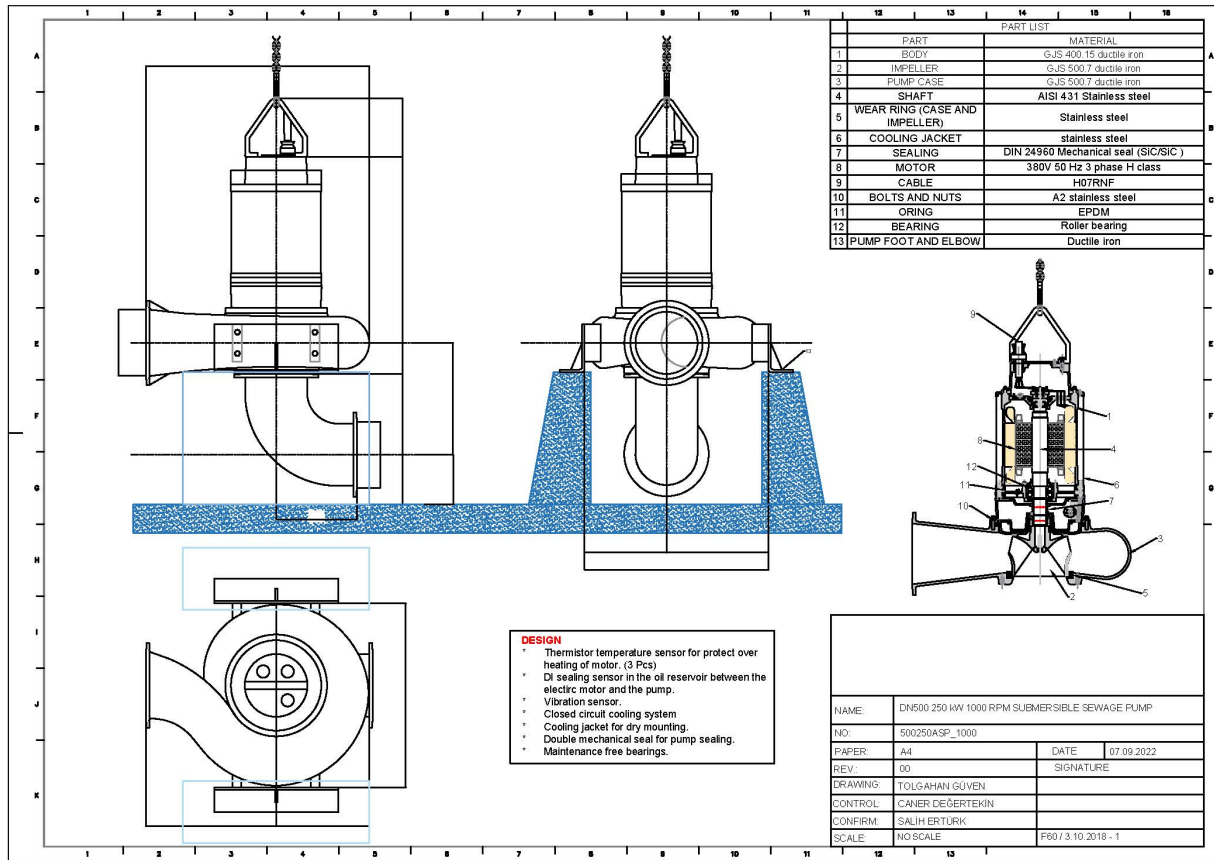

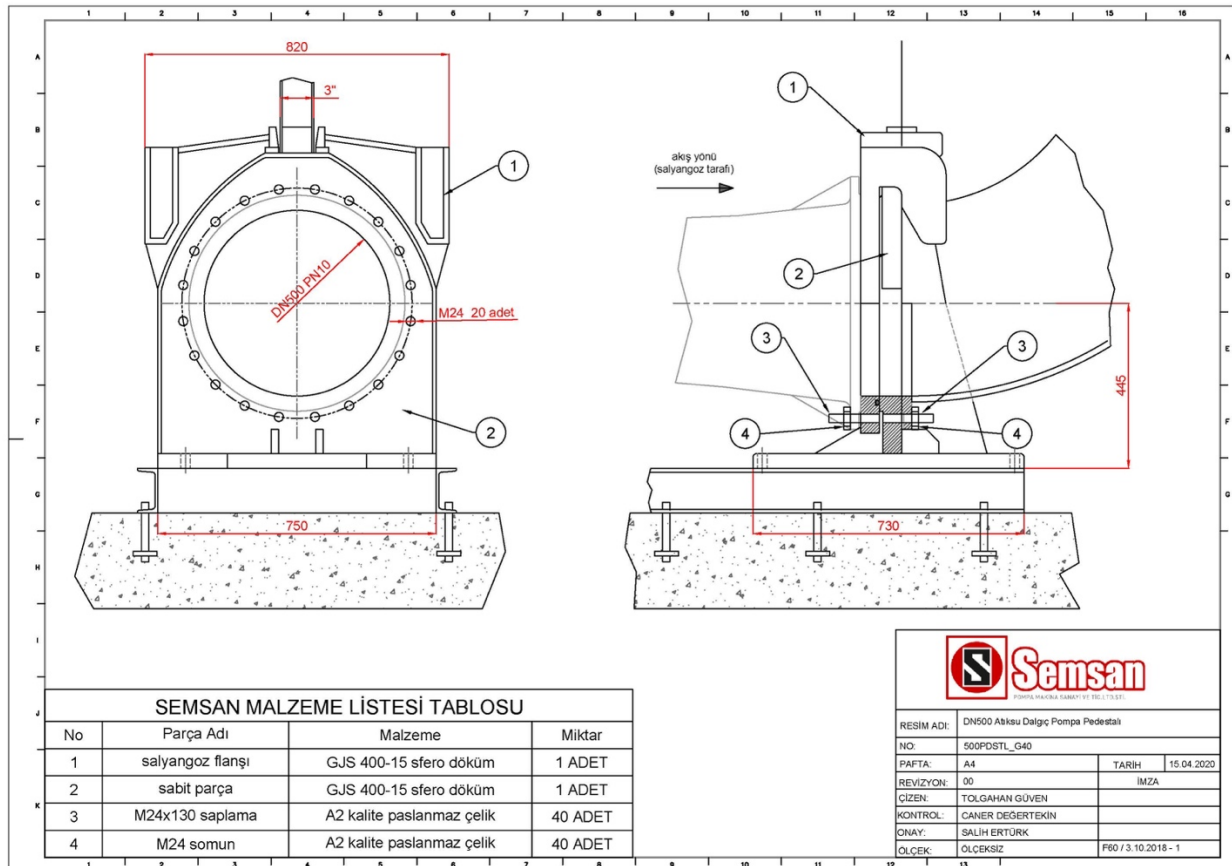
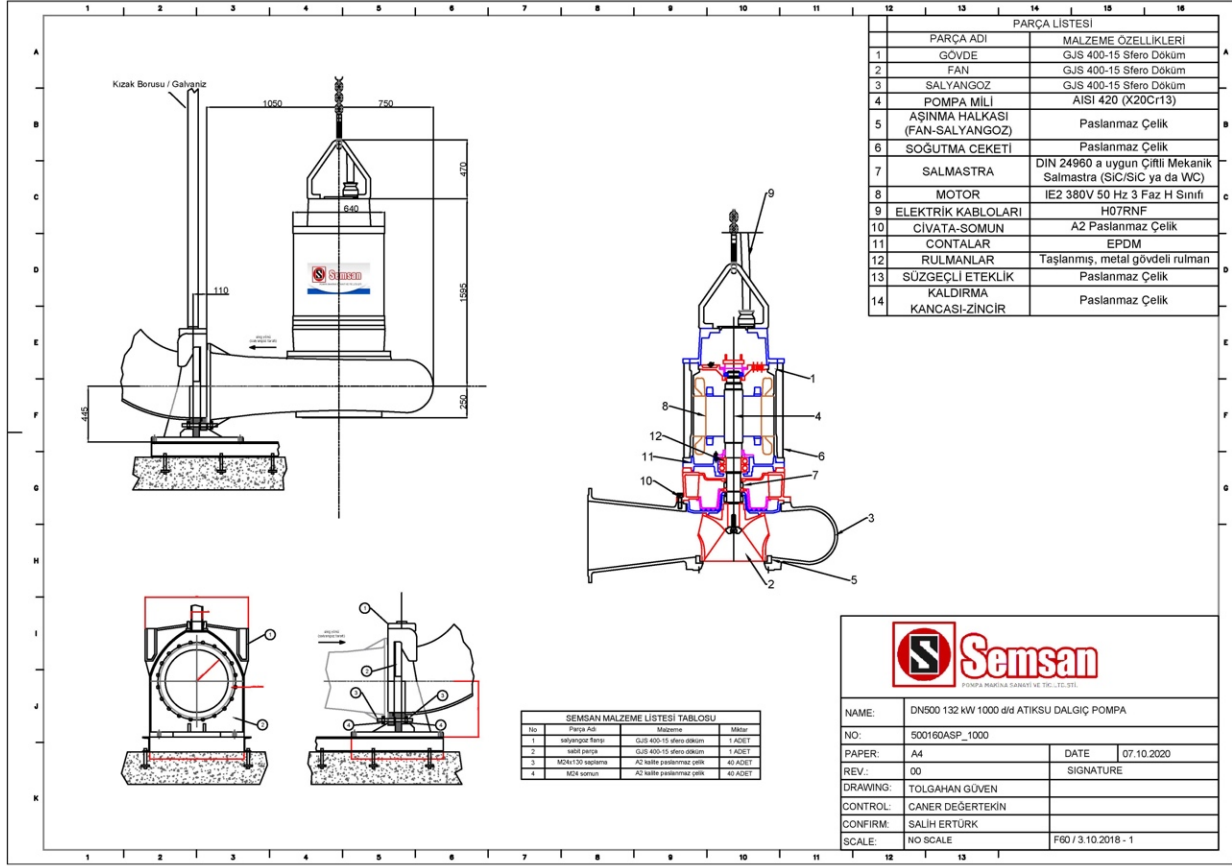

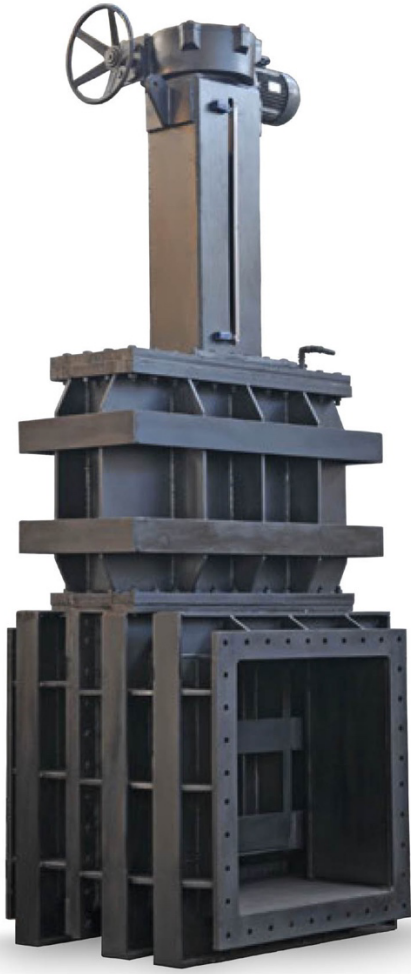

SQUARE SLIDE GATE VALVE

350x350 / 2000x2000

This valve is using for regulating valve and discharge valve at the dams and lakes.

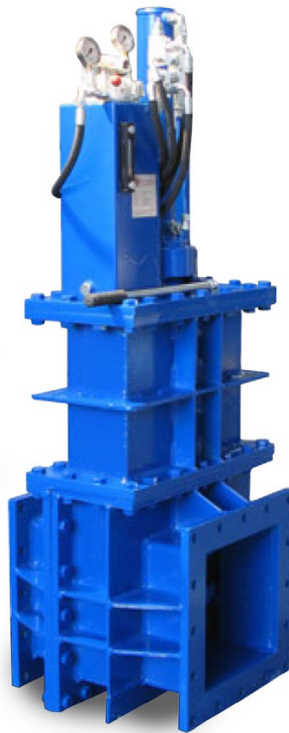

DESIGN

- Special design for operating pressure
- Completely steel construction
- Sealing surfaces are stainless steel
- Gate level indicator
- Special design square flanges
- Handwheel operated

MATERIAL

- Body and gate steel construction EN12516-1
- Stainless steel sealing surfaces
- Valve shaft stainless steel AISI 420

CORROSION PROTECTION

- Epoxy coating for drinking water
- Zinch rich epoxy primer
- Coal-tar epoxy coating

OPTIONAL

- Electric actuator
- Hydraulic actuator
- Input- output transition parts



HOLLOW JET VALVE (Conical Valve)

DN300 - 2000 | PN10 - 16

Two – part control valve insisting of a body and sleeve cylinder.
End of line and bottom outlet discharge valve



DESIGN

- Flanges are EN 1092
- Axial symmetrical flow direction
- High discharge capacity
- Special sealing between cylindrical sleeve and body (soft seal)
- Body surface stainless steel coating
- Low operation force
- Double cylinder hydraulic control mechanism

MATERIAL

- Body and sleeve pipe is steel construction EN12516-1
- Sleeve-mainbody contact surface stainless steel
- Special profile EPDM sealing ring

OPTIONAL

- DN > 2000
- PN > 16
- Pipeline fittings (welded design)

CORROSION PROTECTION

- Epoxy coating for drinking water
- Zinch rich epoxy primer
- Coal-tar epoxy coating

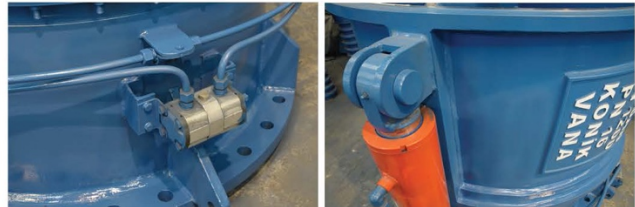

LAST QUALITY CONTROL EN 12266 – 1 CLASS A

Nominal Diameter (DN)	Nominal Pressure PN kg / cm ²	Test Pressure Body	Max Pressure for Temperature 50 °C
300.....2000	10	15	10
300.....2000	16	24	16

* All of dimensions and explanations has been given for information. SEMSAN reserve right to keep change all them off.

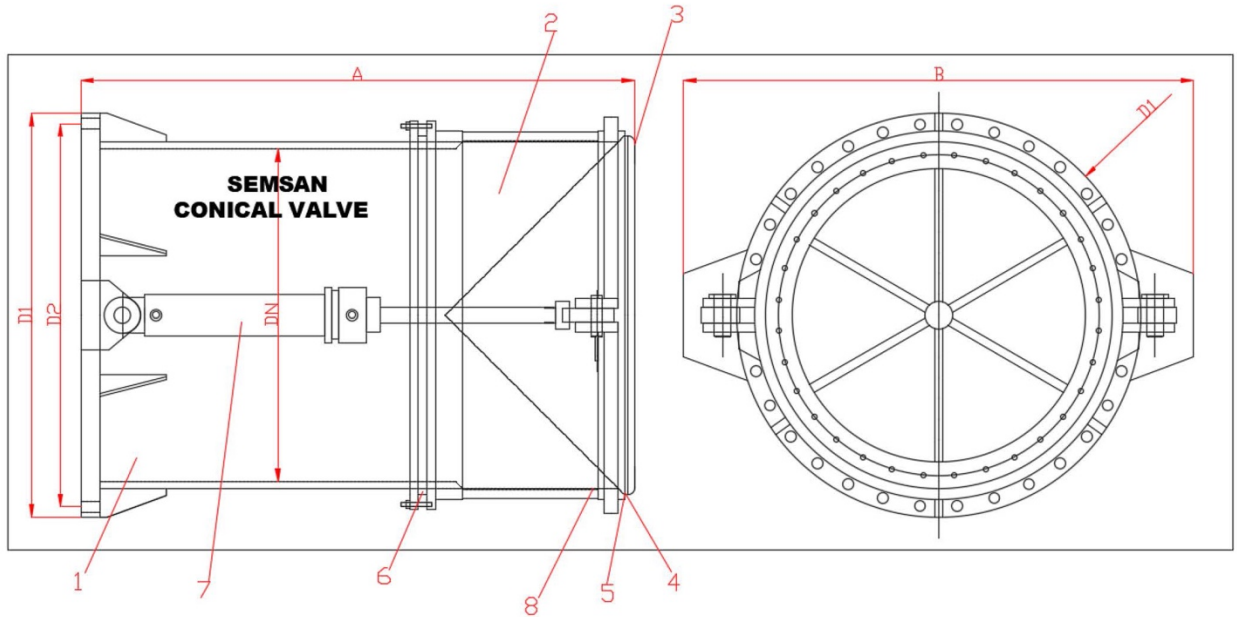

SEMSAN CONICAL VALVE MATERIAL LIST			
NO	PART NAME	MATERIAL	PIECE
1	Body	S235 JR (ST-37)	1
2	Adjusting sleeve	S235 JR (ST-37)	1
3	Sealing ring	S235 JR (ST-37)	1
4	Sealing rubber	EPDM	1
5	Sealing surface	AISI304 Stainless Steel	1
6	Salmastra Sealing ring	S235 JR (ST-37)	1
7	Hydraulic cylinder		2
8	Piston inner sealing surface	AISI304 Stainless Steel	1

SEMSAN CONICAL VALVE DIMENSIONS TABLE							
(DN - PN)	A	B	D1	D2	Number of bolts	Bolts diameter	(KG)
DN400 PN10	750	760	565	515	16	M24	600
DN500 PN10	1000	1000	670	620	20	M24	800
DN600 PN10	1250	1120	780	725	20	M27	1200
DN700 PN10	1500	300	895	840	24	M27	1600
DN800 PN10	1650	1440	1015	950	24	M30	2000
DN900 PN10	1800	1540	1115	1050	28	M30	2400
DN1000 PN10	1900	1650	1230	1160	28	M33	2800
DN1200 PN10	2000	1850	1455	1380	32	M36	4000
DN1400 PN10	2150	1970	1675	1590	36	M39	5200
DN1500 PN10	2250	2070	1785	1700	36	M39	6000

NOTE: Please contact for different diameters. Conical valves are manufactured with a special design. The dimensions in the manufacturing projects to be prepared according to the operating pressure and conditions may differ from the table above.



Sleeve Type Free Discharge Valve

DD1113

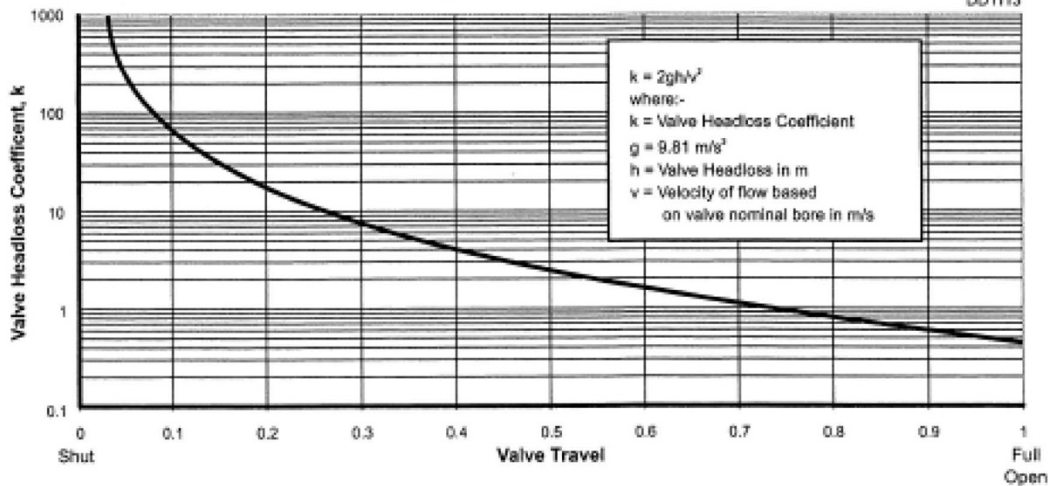

Valve Selection Chart

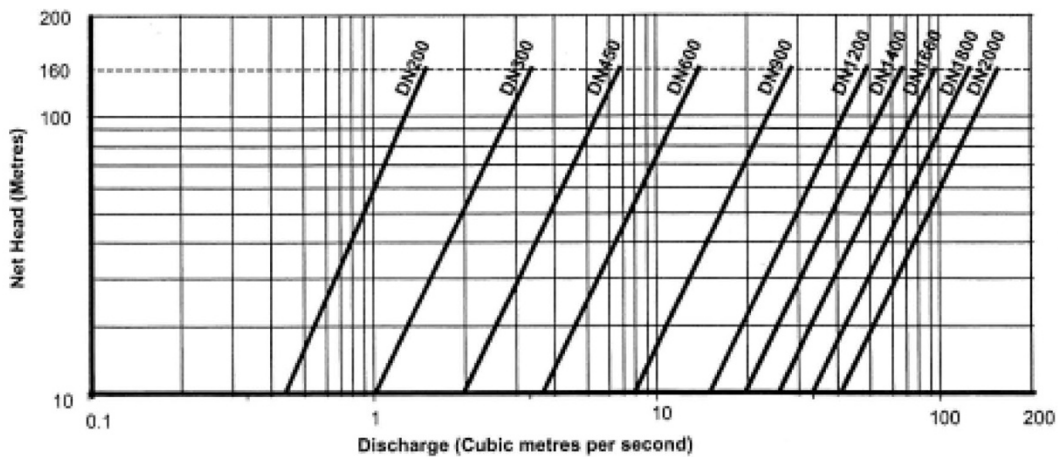

- $Q = C \times \sqrt{2gH} \times A$
 C = Coefficient of discharge with the valve full open (0.83)
 g = 9,8 m/s²
 H = Net head in metres (m)
 A = Area of the valve based on the nominal valve diameter (m²)

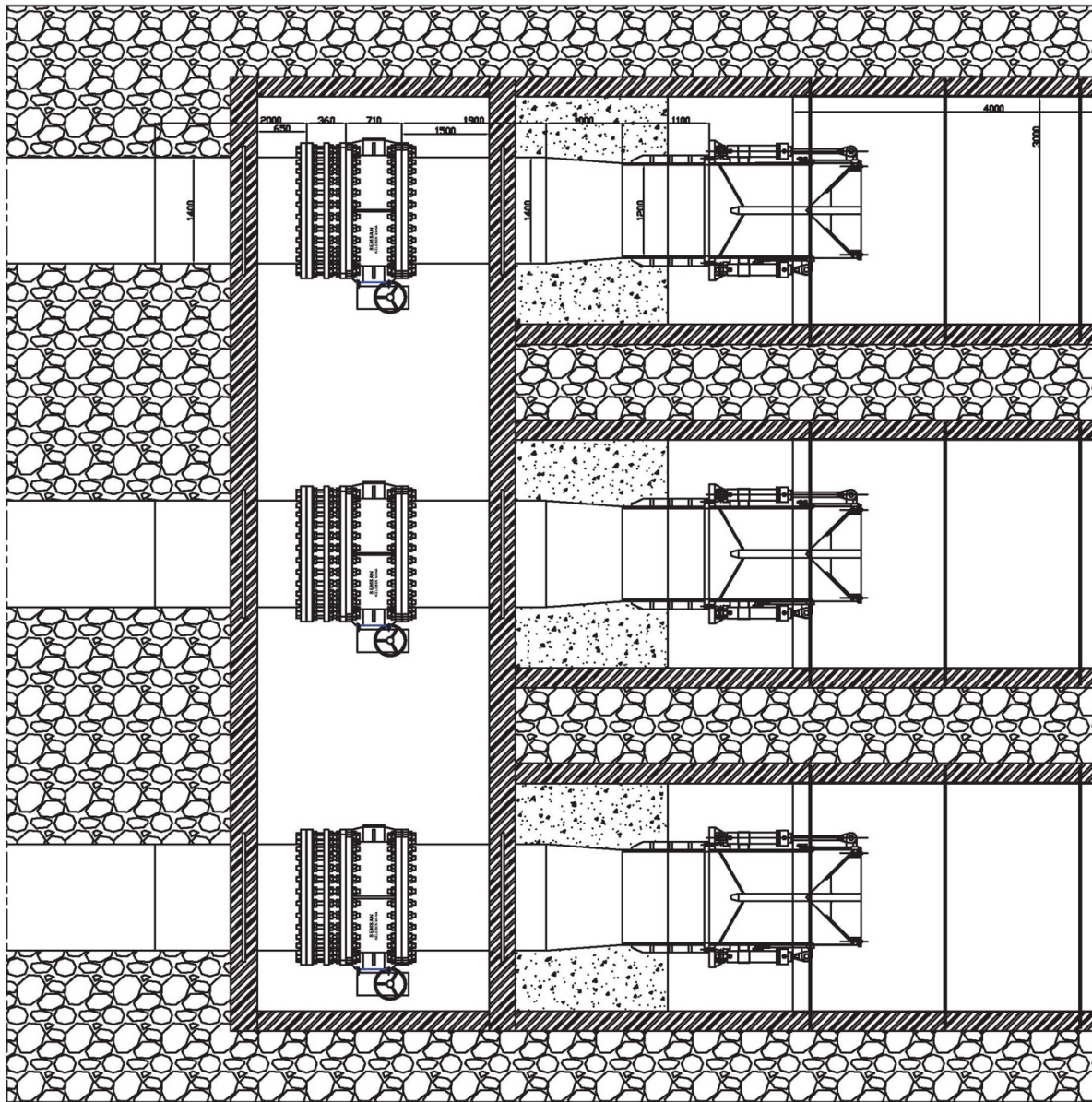
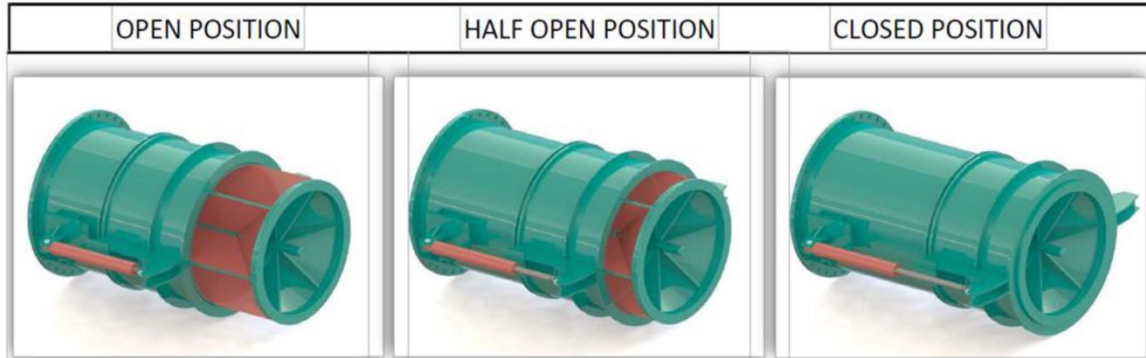

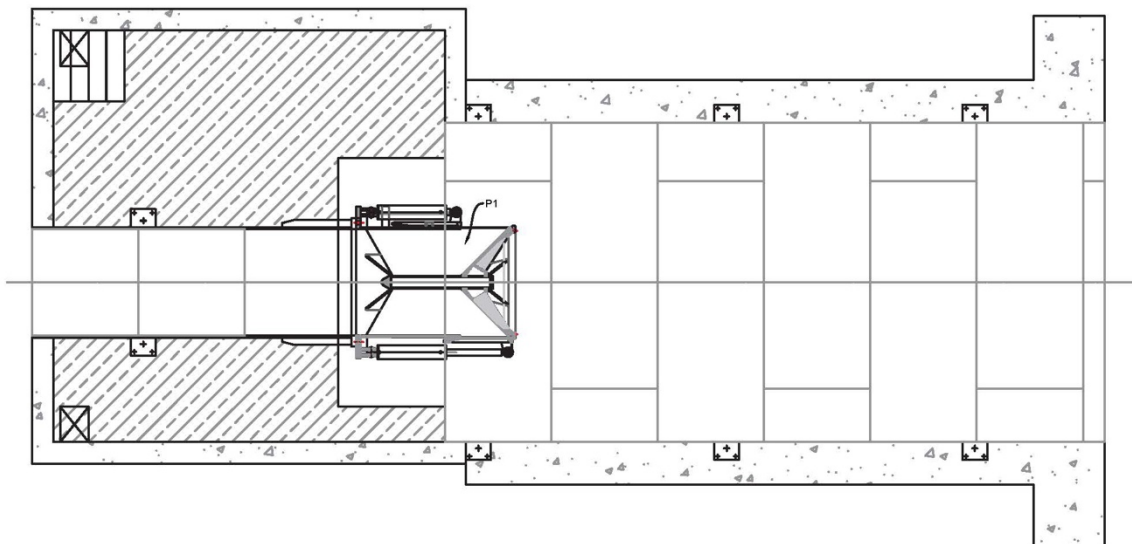
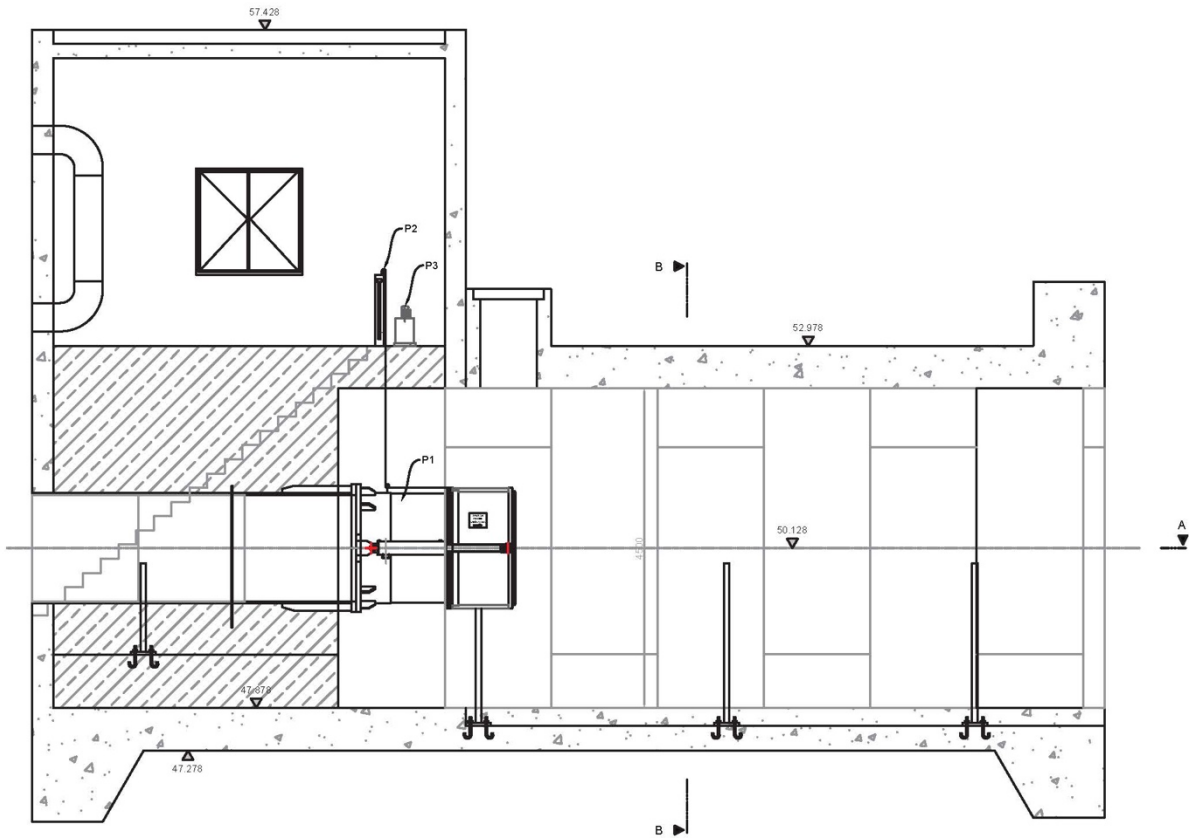





PUMP, VALVE & DAM
EQUIPMETS
PRODUCT CATALOGUE

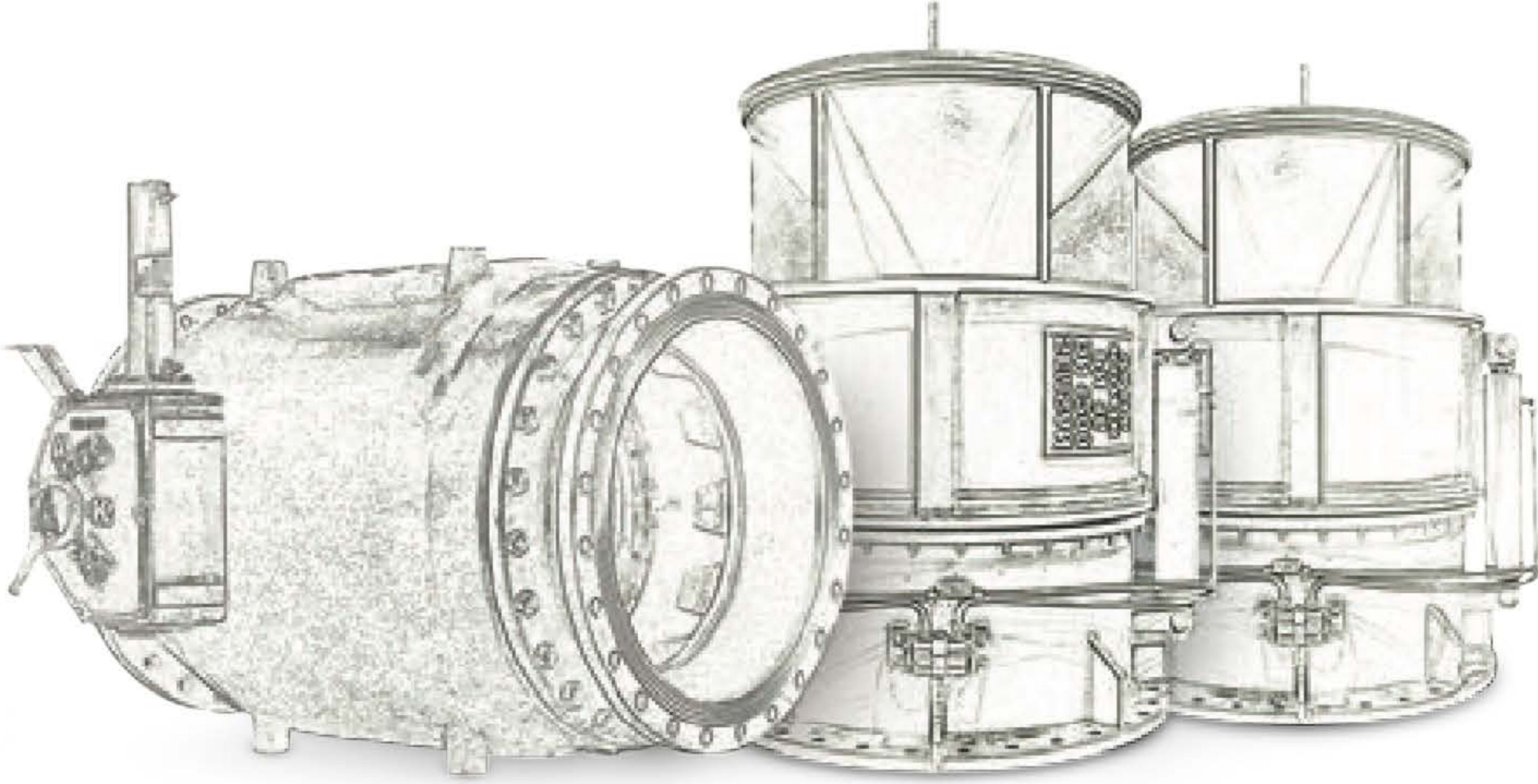

SEMSAN POMPA MAKİNA SANAYİ VE TİCARET LTD. ŞTİ.

Address : Organize Sanayi Bölgesi Erdoğan Cebeci Bulvarı.
No:42/B Kutlukent / SAMSUN / TURKEY

Phone : +90 362 266 88 33

Fax : +90 362 266 88 58

E-mail : semsan@semsan.com.tr

Web : www.semsan.com.tr

BASKI 27.08.2016

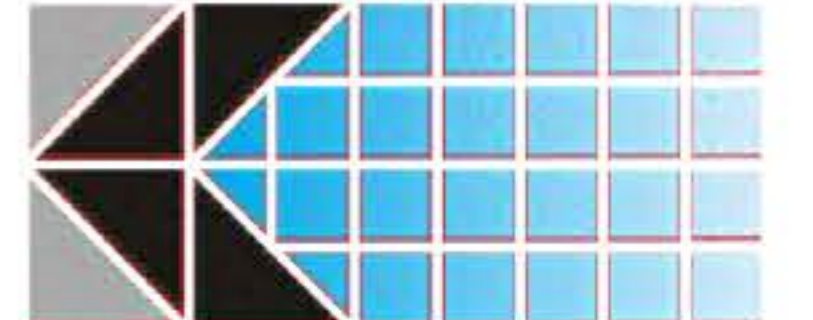

KOSGEB